

Anbauanleitung: Windenkonsole für BAW 212 ab 26

AL: 2447-00

Best.Nr.: 16-5500

Montagezeit: ca. 120 min.

***Hier sehen sie die fertig montierte Windenkonsole.
Bevor sie mit der Montage beginnen, lesen sie bitte diese Anleitung gut durch.***

***Here you can see the fully assembled winch bracket.
Before you start fitting, please read and understand this instruction manual.***



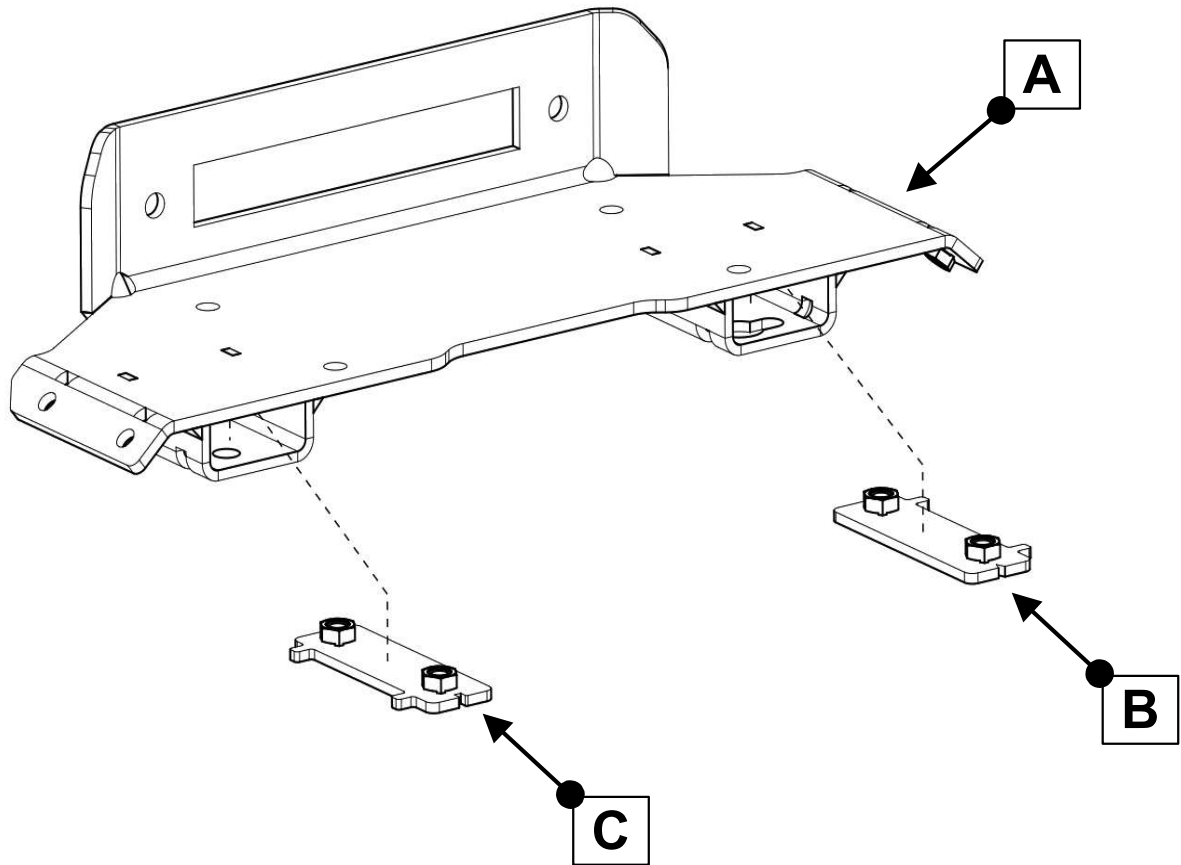

Stückliste

16-550

Schraubensatz

1x Grundplatte (A)
 1x Gegenplatte Rechts (B)
 1x Gegenplatte Links (C)

4x Schraube M10 x 30
 4x Federring M10
 4x Scheibe M10 x 30 x 3

1x Anleitung AL2447

1x Kabel 35mm² schwarz 22cm
 2x Kabelschuh 35mm² M8
 2x Wärmeschrumpfschlauch Ø12mm – 5cm

| Schrauben Anzugsmomente | |
|-------------------------|------------------|
| Schraubengröße | Güteklasse - 8.8 |
| M6 | 10 Nm |
| M8 | 25 Nm |
| M10 | 50 Nm |
| M12 | 87 Nm |
| M14 | 138 Nm |
| M16 | 210 Nm |

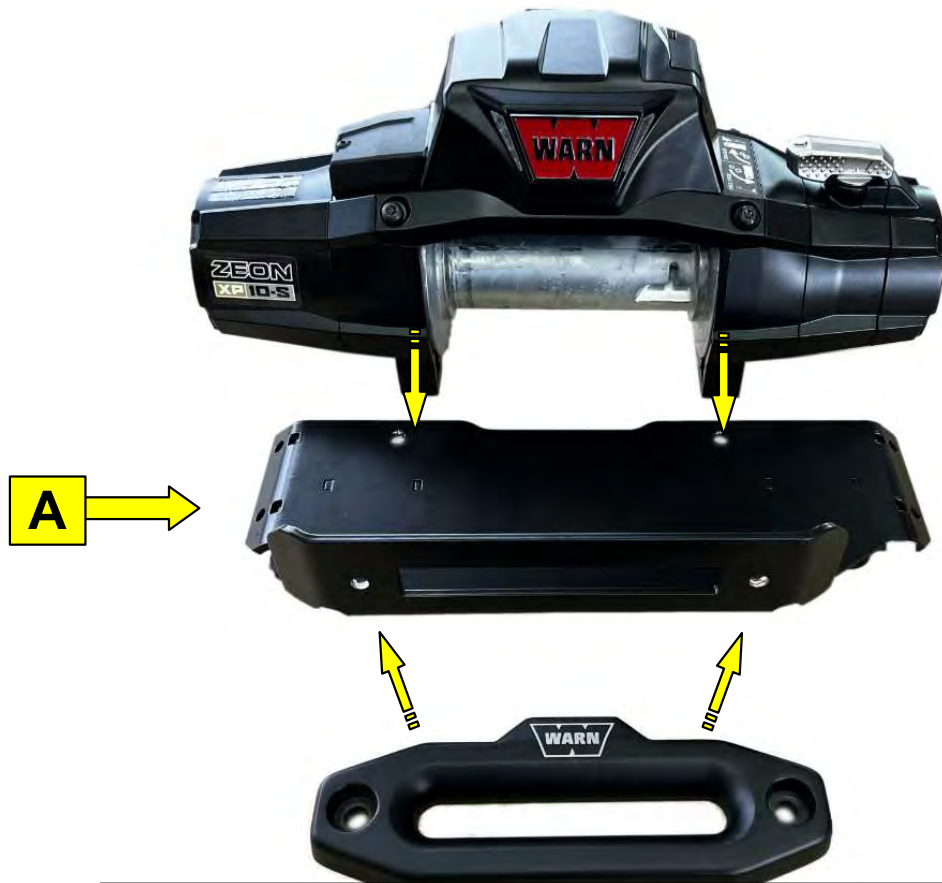

1

Windenkonsole vorbereiten /
Prepare the winch bracket



2

Seilfenster befestigen /
Secure the rope window

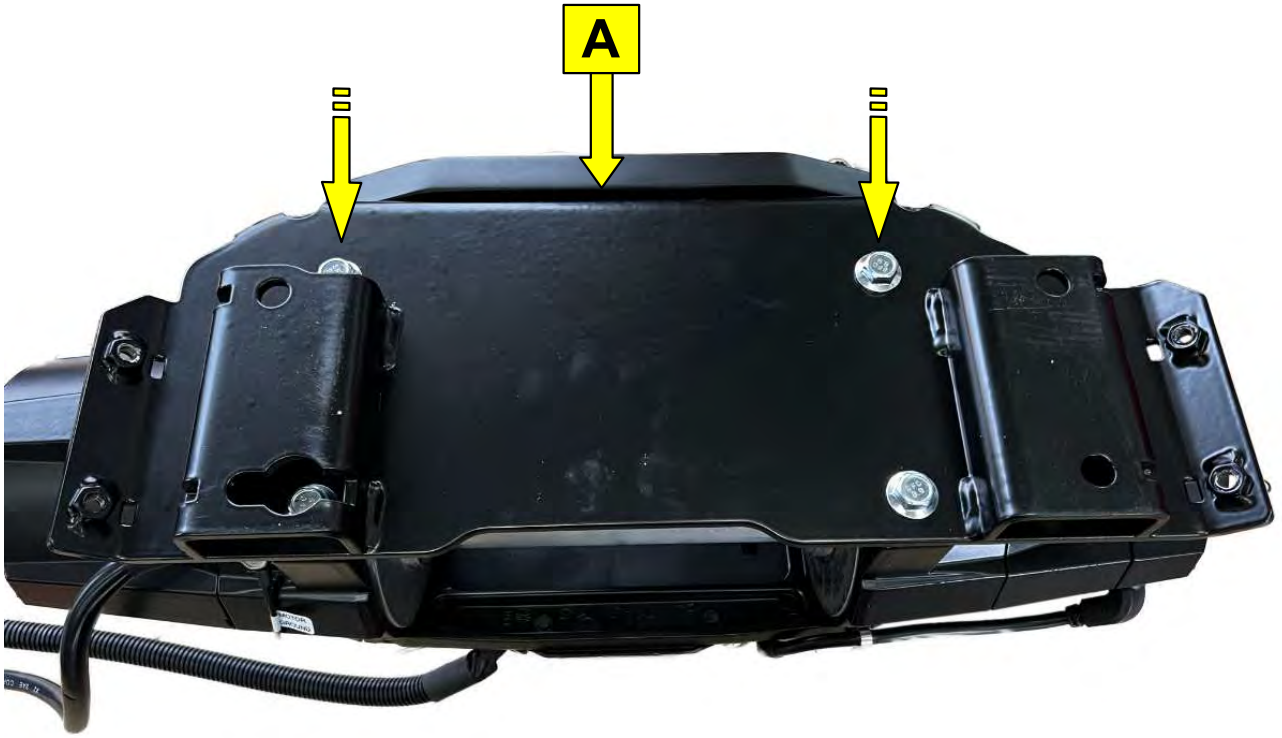

3

**Seilwinde festschrauben /
Secure the winch with bolts**

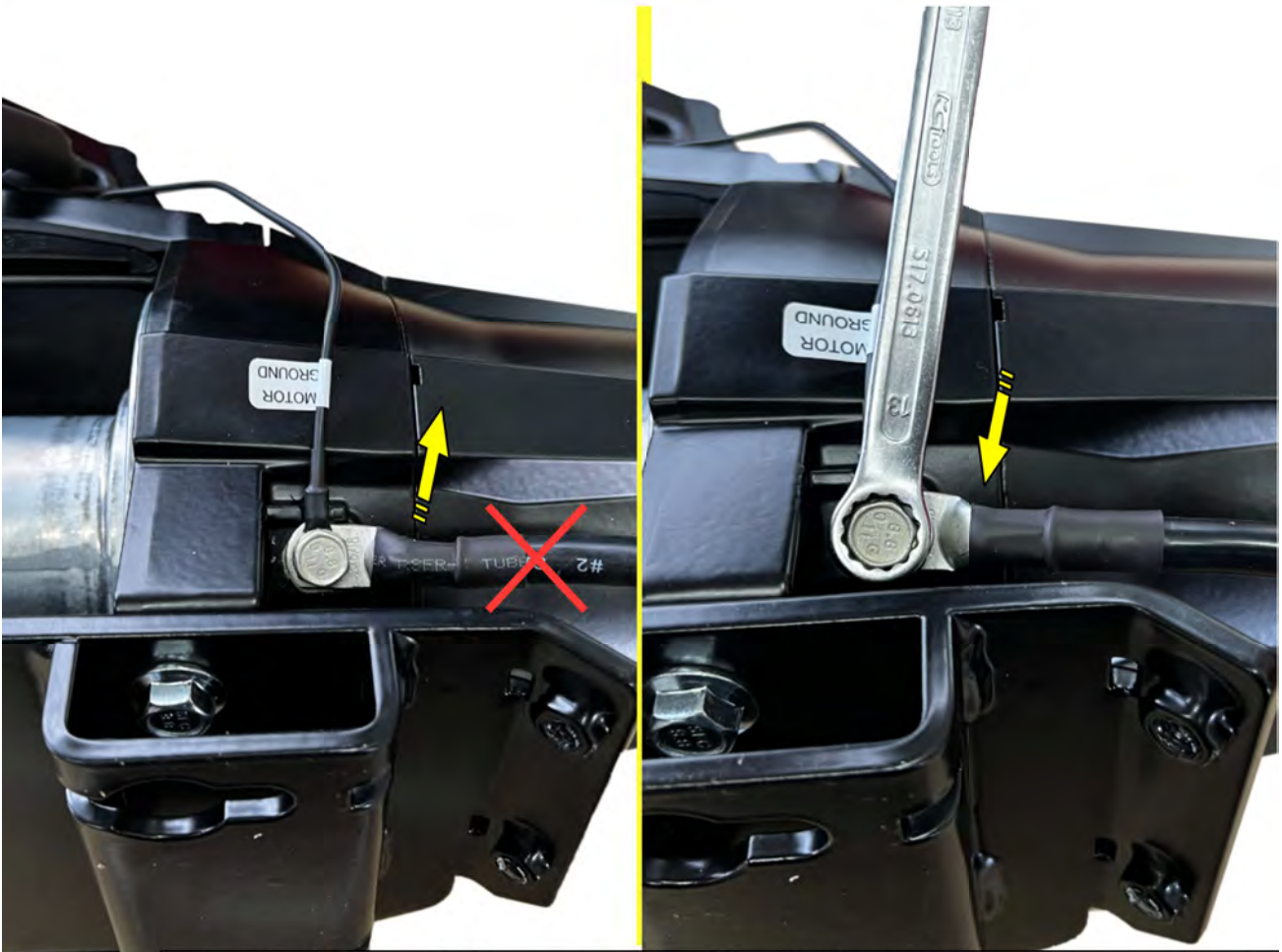

4

**Original Masseleitung gegen mitgelieferte Leitung tauschen /
Replace the original cable with the one provided**

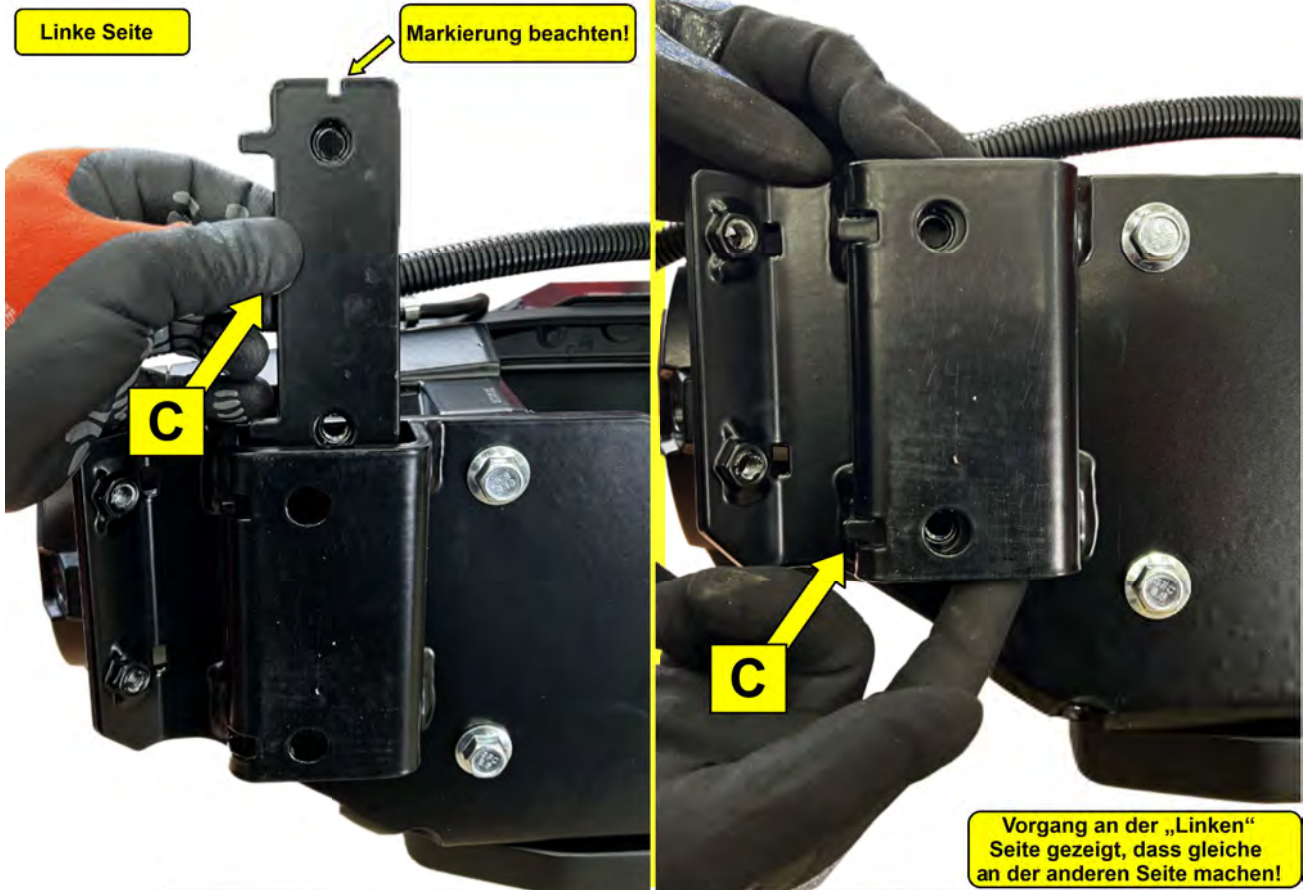

5

**Die Gegenplatten (B + C) in Konsole einschieben /
Insert the counterplates (B + C) into the bracket**



6

**Seil befestigen /
Secure the rope**

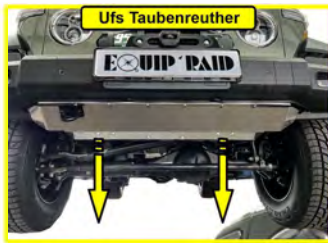

Ufs Taubenreuther

EQUIP RAID



7

**Unterfahrerschutz demontieren /
Remove the underride guard**

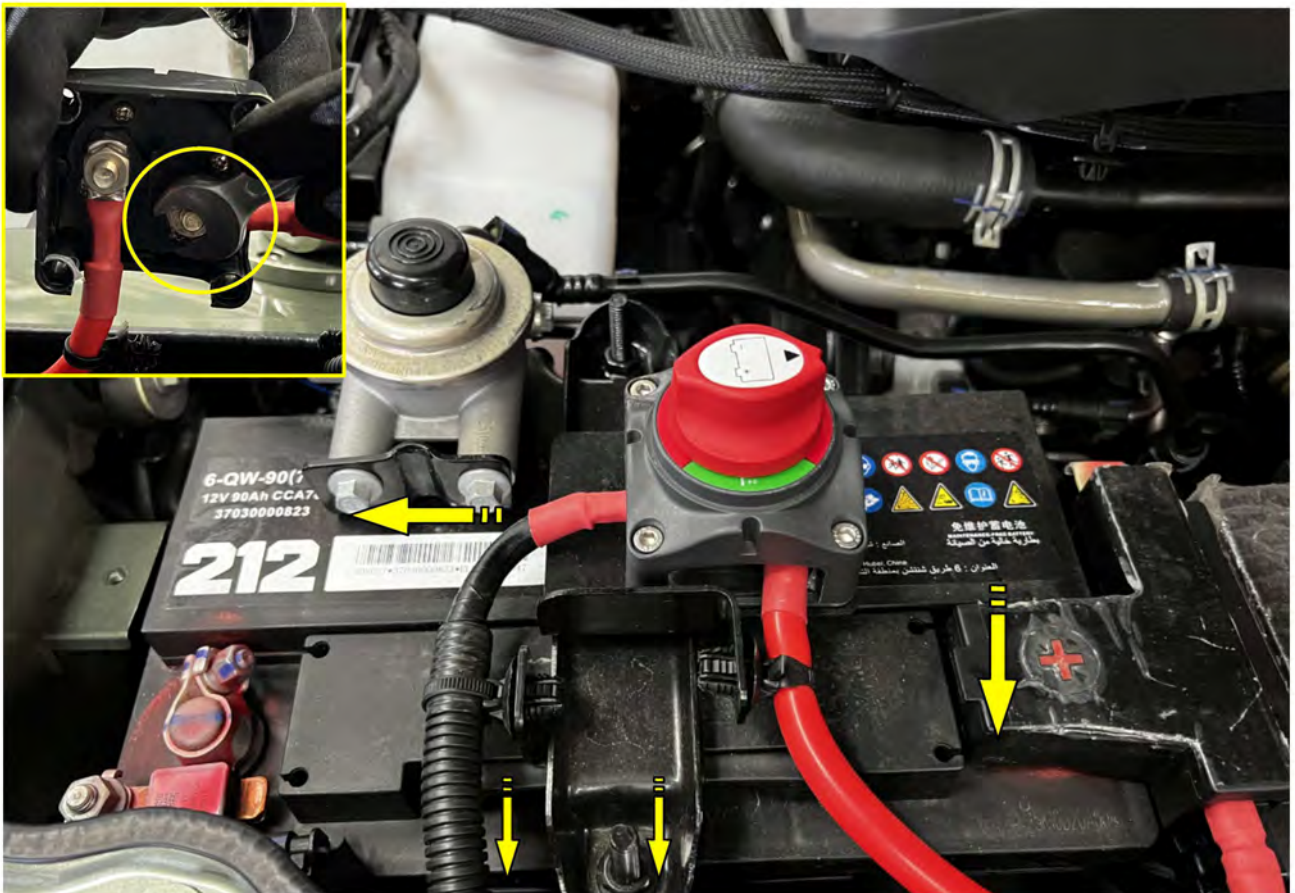

8

**Original Plus- Leitung (Rot) abschließen /
Disconnect the Original Plus wire (red)**



9

**Original Plus- Leitung (Rot) an der Winde abschließen /
Disconnect the Original Plus wire (red) from the winch**



10

**Original Masse- Leitung (Schwarz) an der Winde abschließen /
Disconnect the Original ground wire (black) from the winch**

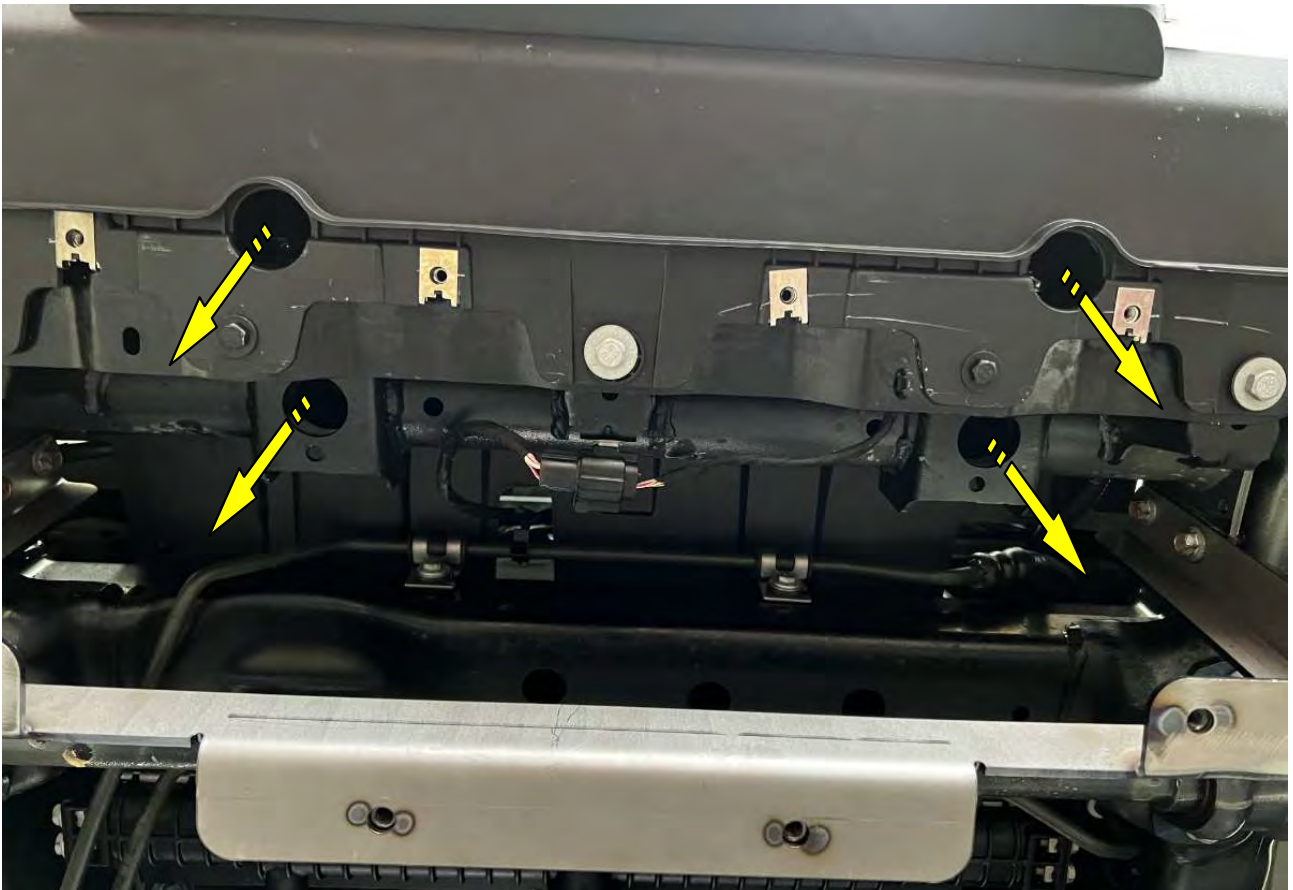

11 Befestigungsschrauben der Winde entfernen /
Remove the winch mounting bolts



12 Jetzt kann die Seilwinde entfernt werden /
Now the winch can be removed



13

**Original Masse- Leitung entfernen /
Remove the original ground wire**



14

**Windenkonsole aufsetzen und Leitung (Rot) durchführen /
Attach the winch bracket and route the cable (red) through it**

Linke Seite

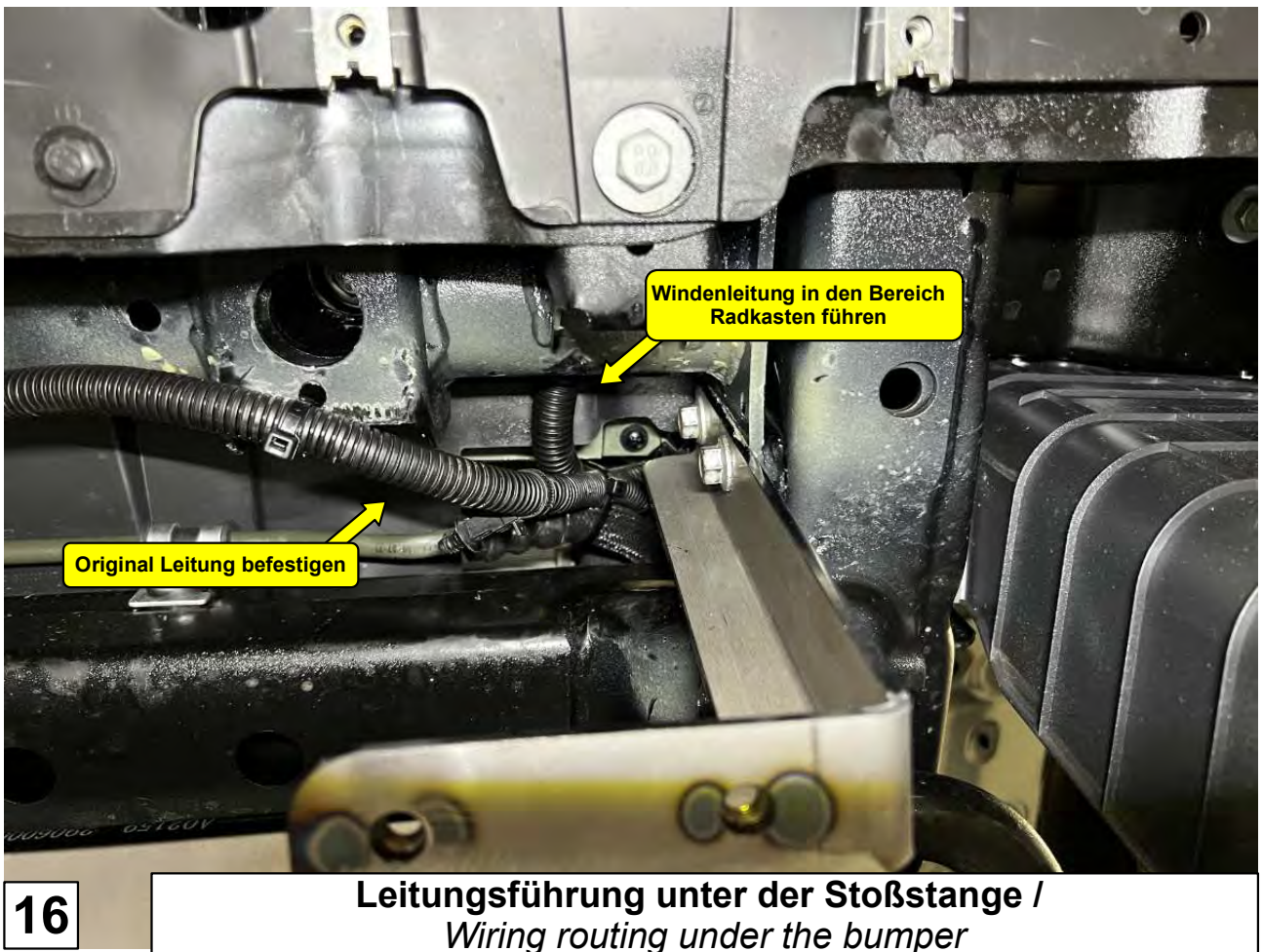
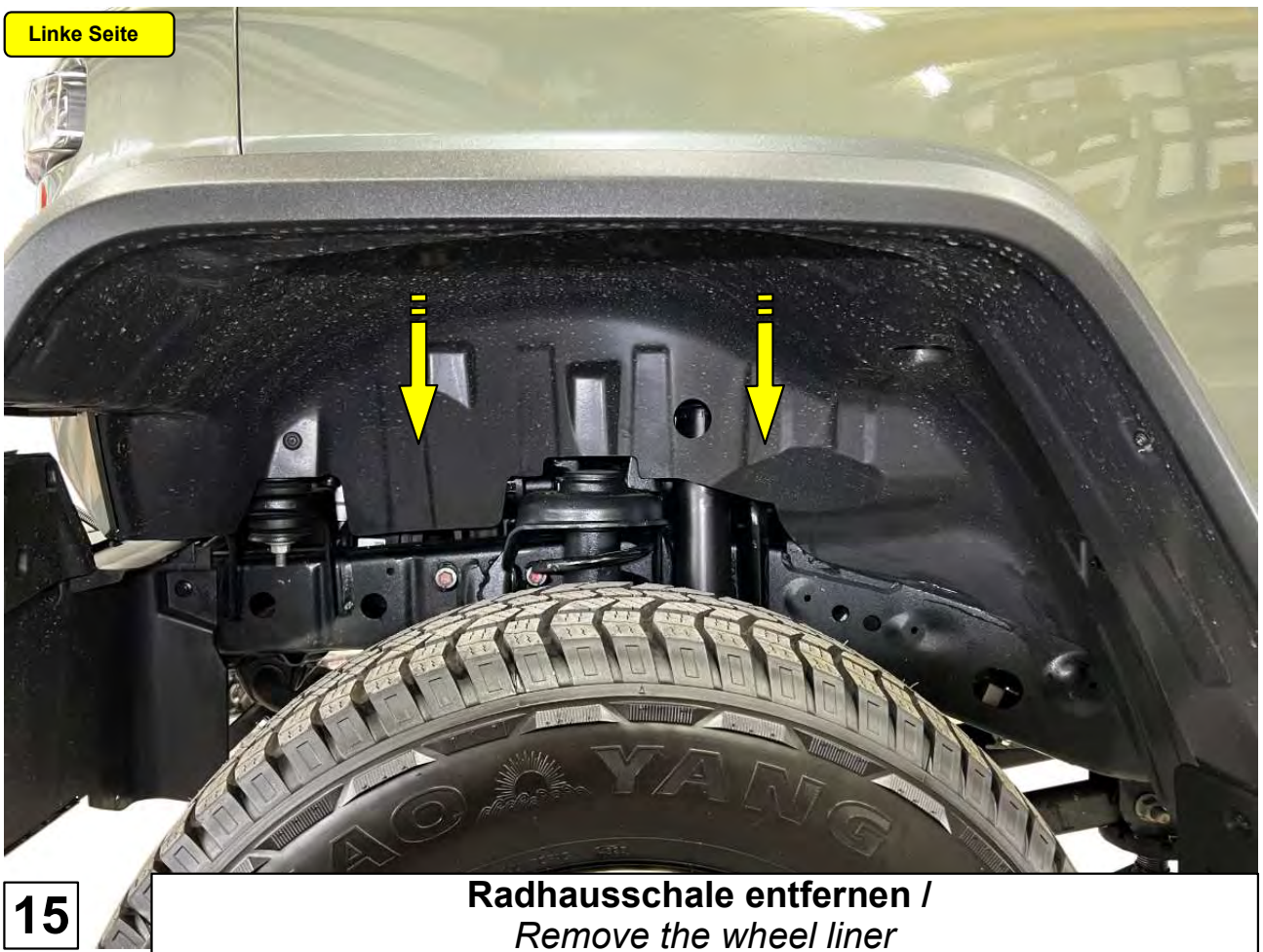

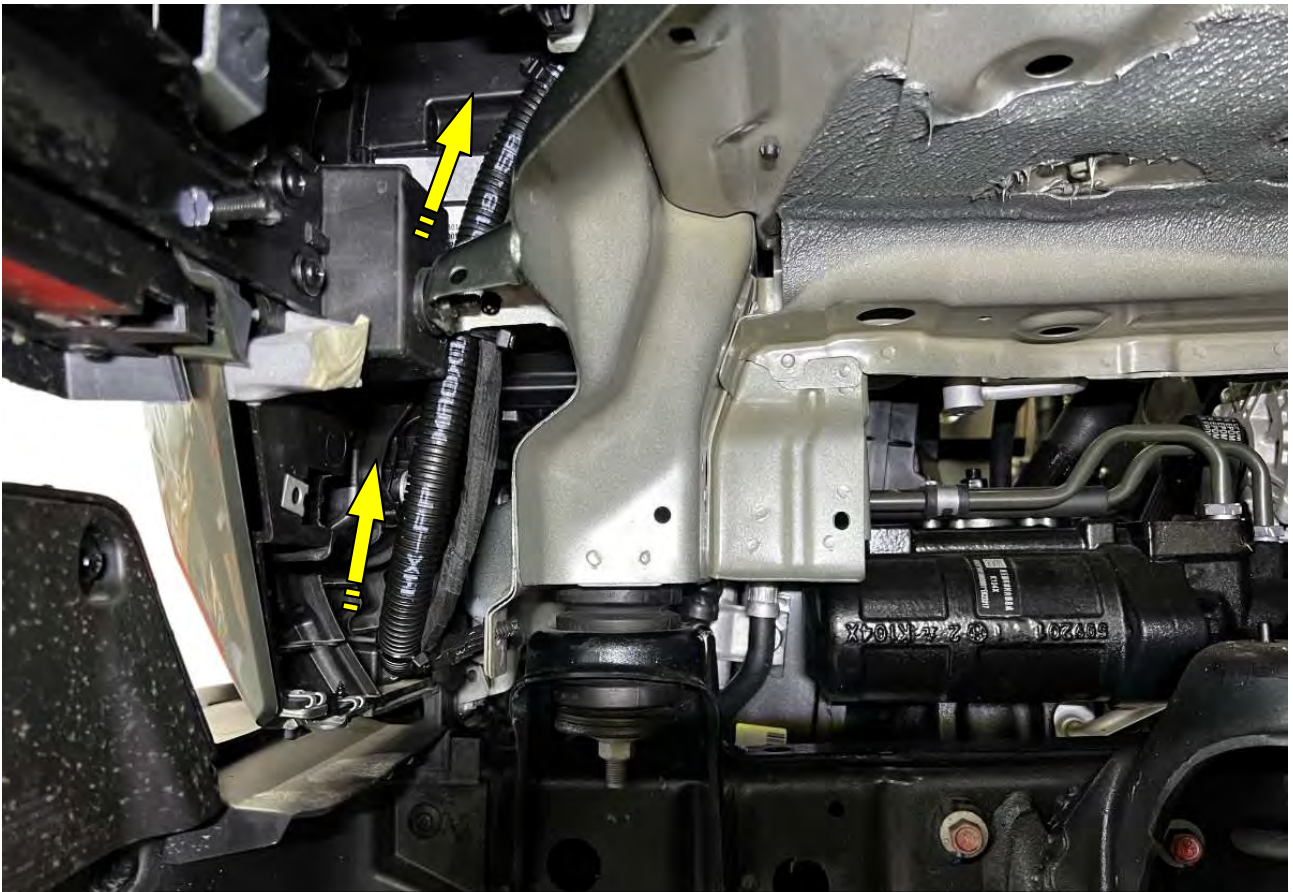

17 Leitungsführung im Bereich Radkasten /
Wire routing in the wheel area

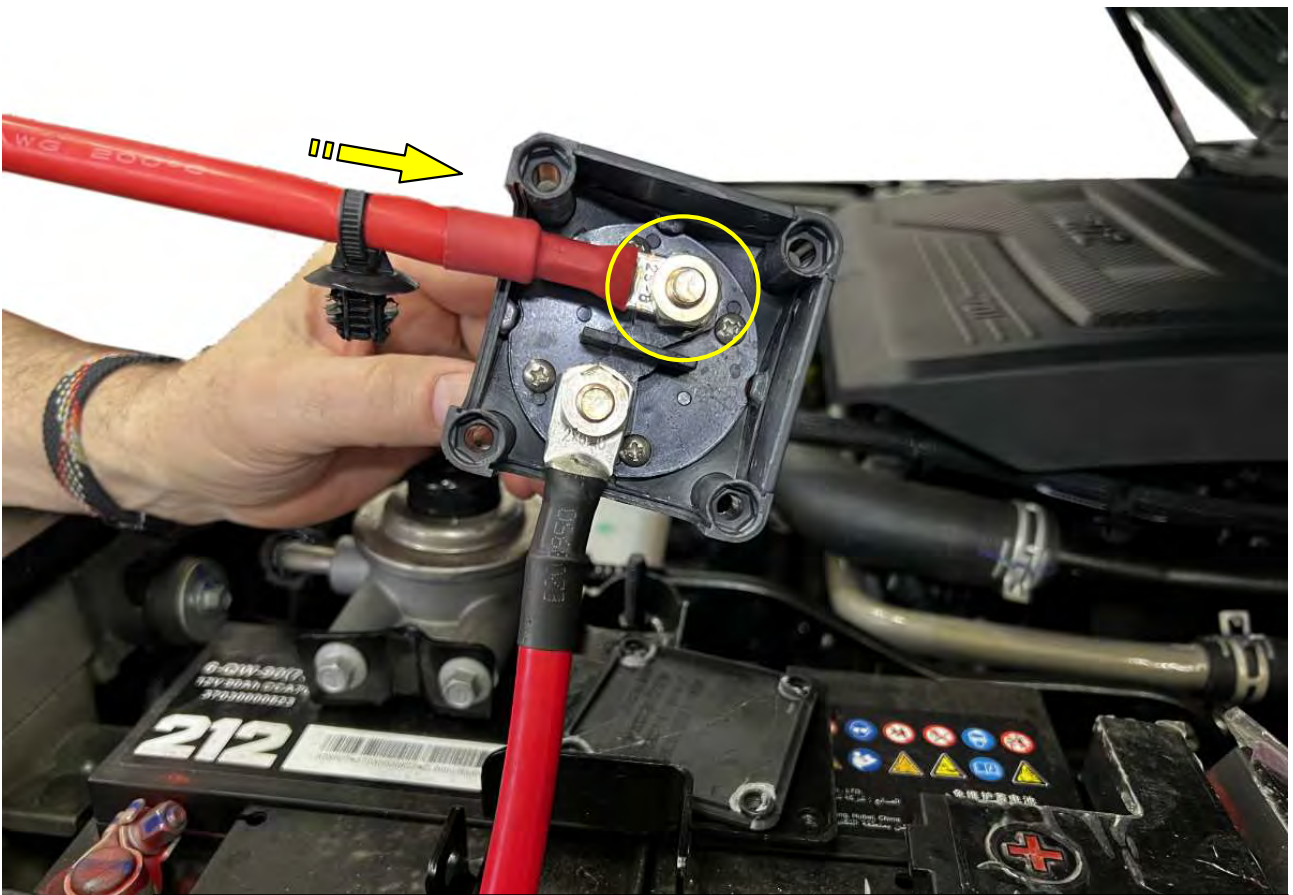

18 Plus- Leitung anschließen und Schalter befestigen /
Connect the positive wire and secure the switch



19

Masse- Leitung am Fahrzeug anschließen /
Connect the ground wire to the vehicle

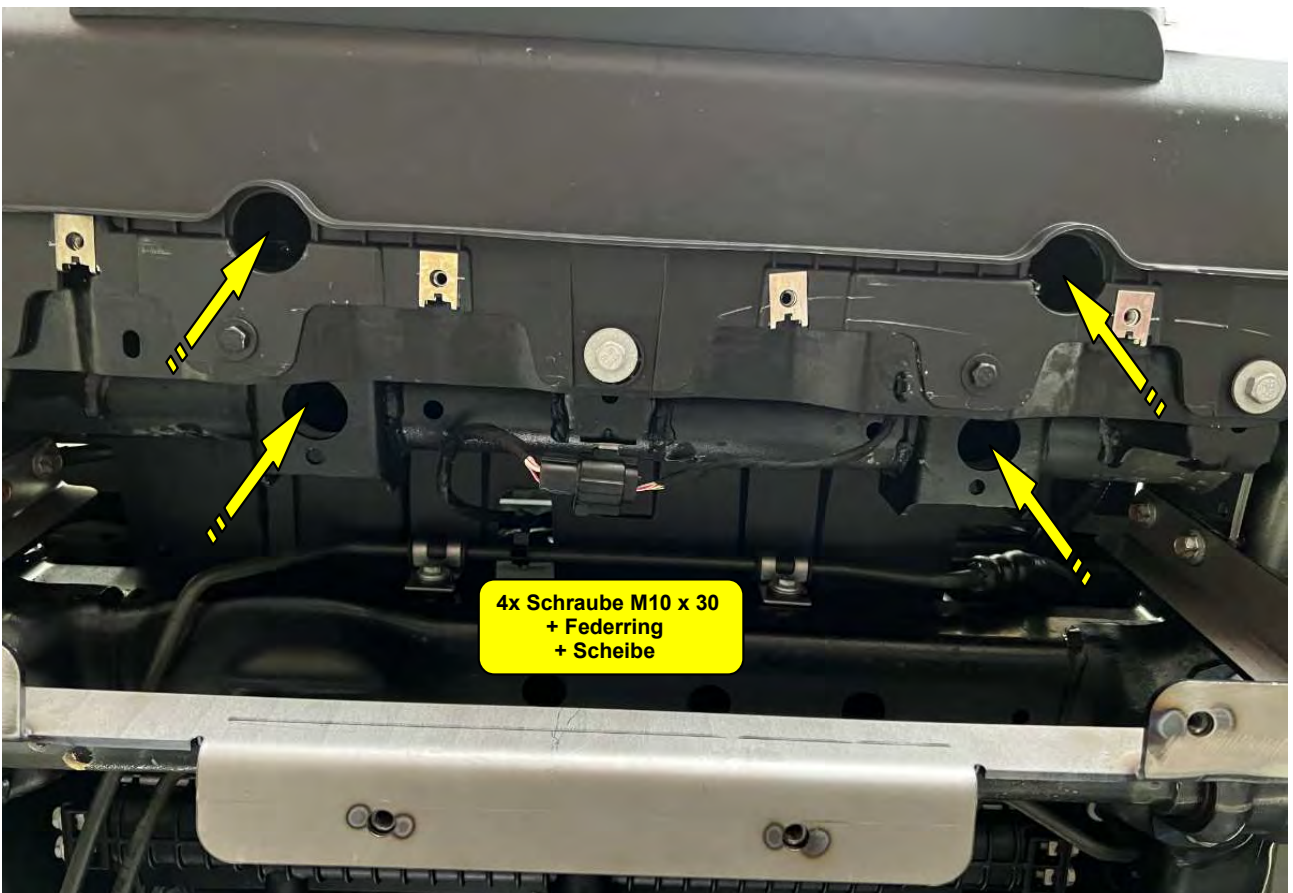

20

Seilwindenkonsole befestigen /
Remove the winch mounting bolts

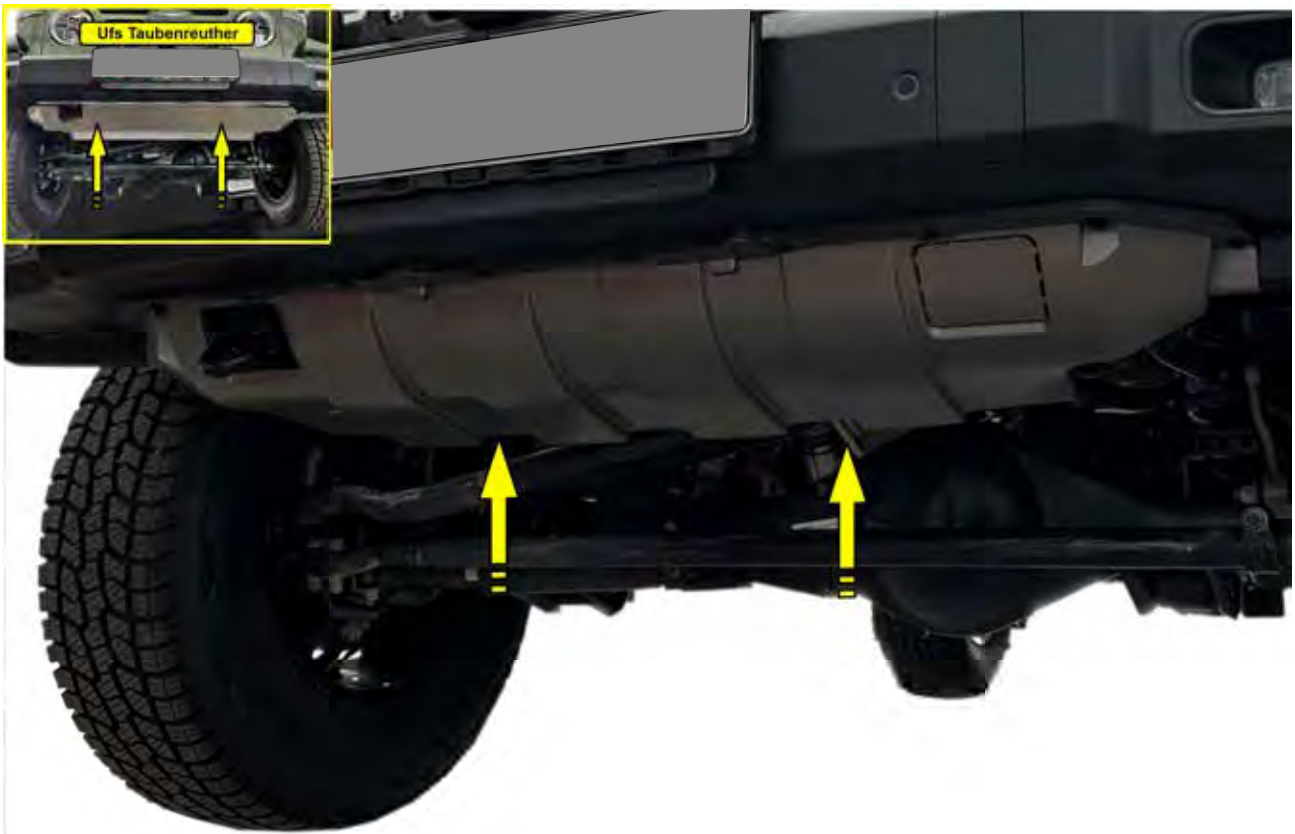

21

Unterfahrerschutz wieder montieren /
Reinstall the underride guard

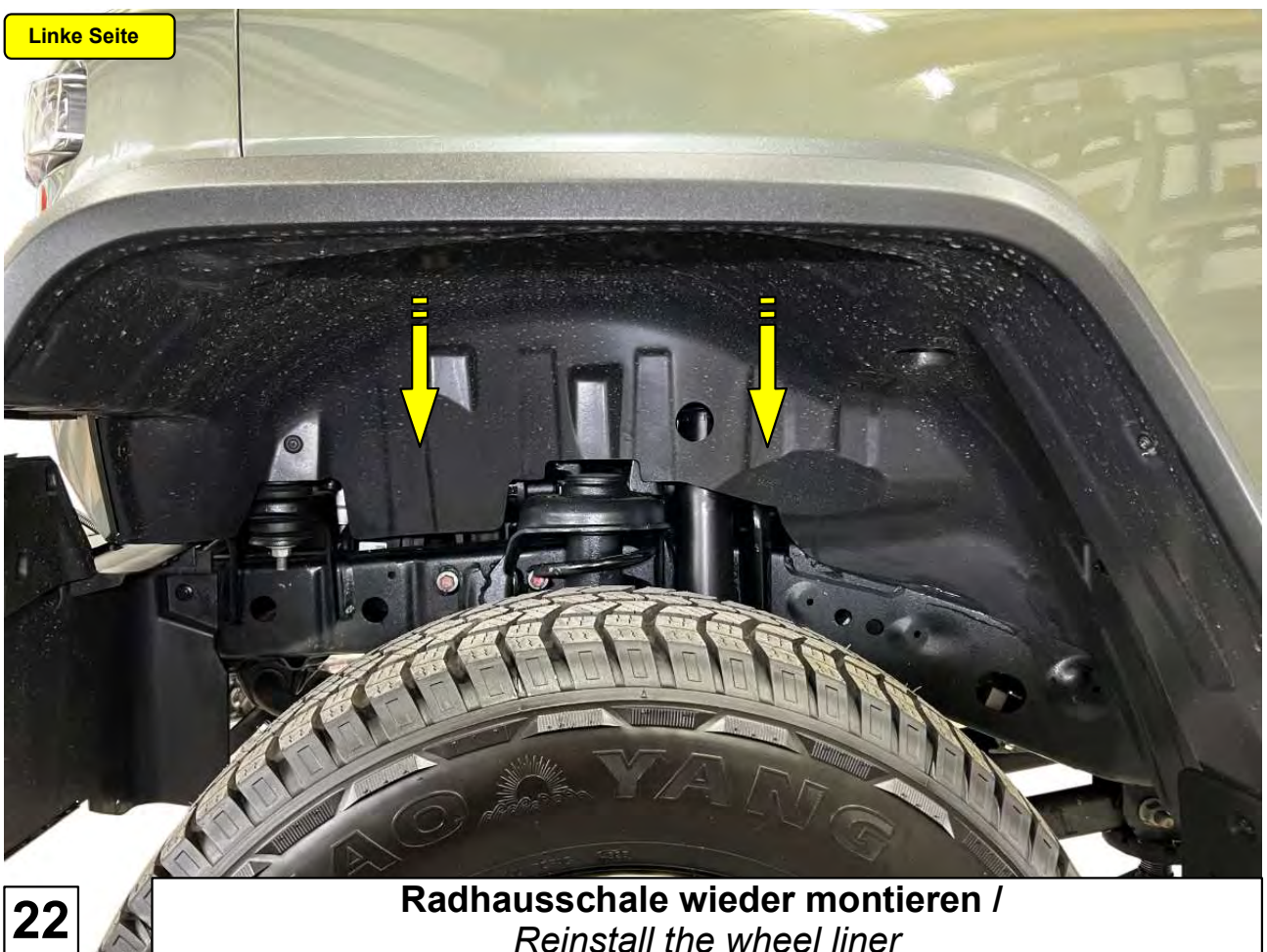

22

Radhausschale wieder montieren /
Reinstall the wheel liner



23

Seil aufspulen und Fertig /
Wind the rope onto the spool and you're done