

# START HERE! READ ME FIRST

Don't be a hero and muscle through this installation without reading these fitting instructions first! Improper installation of this gear may void certain aspects of your warranty.

Before you begin, take a moment and open all your Front Runner rack kit boxes and gather the assembly instructions for the various components.

A complete kit will contain:

1. A Front Runner Mounting System specific to your vehicle
2. A Front Runner Rack Tray or Load Bar Slats

This document will guide you through the assembly of the mounting system and assist you in fitting the roof rack tray or load bars to your specific vehicle.

Please refer to the next page for a list of all the components, quantities and tools required.

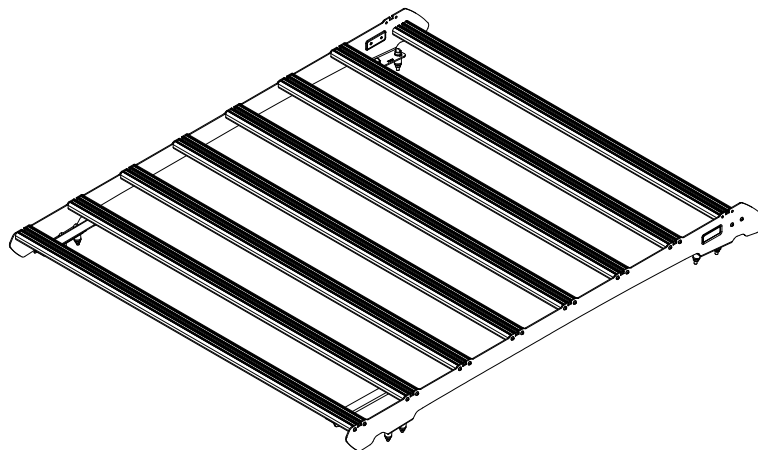

## IMPORTANT WARNING!

IT IS CRITICAL THAT ALL FRONT RUNNER PRODUCTS BE PROPERLY AND SECURELY ASSEMBLED AND ATTACHED TO YOUR VEHICLE. IMPROPER ATTACHMENT COULD RESULT IN AN AUTOMOBILE ACCIDENT, AND COULD CAUSE SERIOUS BODILY INJURY OR DEATH. YOU ARE RESPONSIBLE FOR ASSEMBLING AND SECURING ALL FRONT RUNNER PRODUCTS TO YOUR VEHICLE, CHECKING THE ATTACHMENTS PRIOR TO USE, AND PERIODICALLY INSPECTING THE PRODUCTS FOR ADJUSTMENT, WEAR AND DAMAGE. THEREFORE, YOU MUST READ AND UNDERSTAND ALL OF THE INSTRUCTIONS AND PRECAUTIONS SUPPLIED WITH YOUR FRONT RUNNER PRODUCT PRIOR TO INSTALLATION OR USE. IF YOU DO NOT UNDERSTAND ALL OF THE INSTRUCTIONS AND CAUTIONS, OR IF YOU HAVE NO MECHANICAL EXPERIENCE AND ARE NOT THOROUGHLY FAMILIAR WITH THE INSTALLATION PROCEDURES, YOU SHOULD HAVE THE PRODUCT INSTALLED BY A PROFESSIONAL INSTALLER OR OTHER QUALIFIED PERSONNEL.

**NOTE:** Front Runner will not be responsible for any damage caused by the failure to install the product according to these instructions.

Please call us if you have any questions about the installation of this product.



# 1 GET ORGANIZED

## IN THE BOX

|    |      |                                 |
|----|------|---------------------------------|
| 1  | 2 X  | Foot Rail - 1 LH & 1 RH         |
| 2  | 8 X  | Narrow Slat - 1289mm Long       |
| 3  | 2 X  | Stiffener Bracket - 1 LH & 1 RH |
| 4  | 8 X  | Aluminium Spacer - 22mm High    |
| 5  | 16 X | M8 x 19 x 2 Flat Washer         |
| 6  | 12 X | M8 Nyloc Nut                    |
| 7  | 8 X  | M8 x 50 Hex Bolt                |
| 8  | 12 X | M8 Nut Cap                      |
| 9  | 4 X  | M8 x 20 Hex Bolt                |
| 10 | 32 X | M6 x 20 Button Head Bolt        |
| 11 | 4 X  | M8 x 16 x 1.6 Flat Washer       |
| 12 | 1 X  | Thread Locker                   |

## TOOLS NEEDED

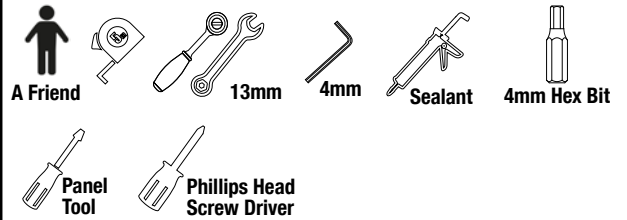
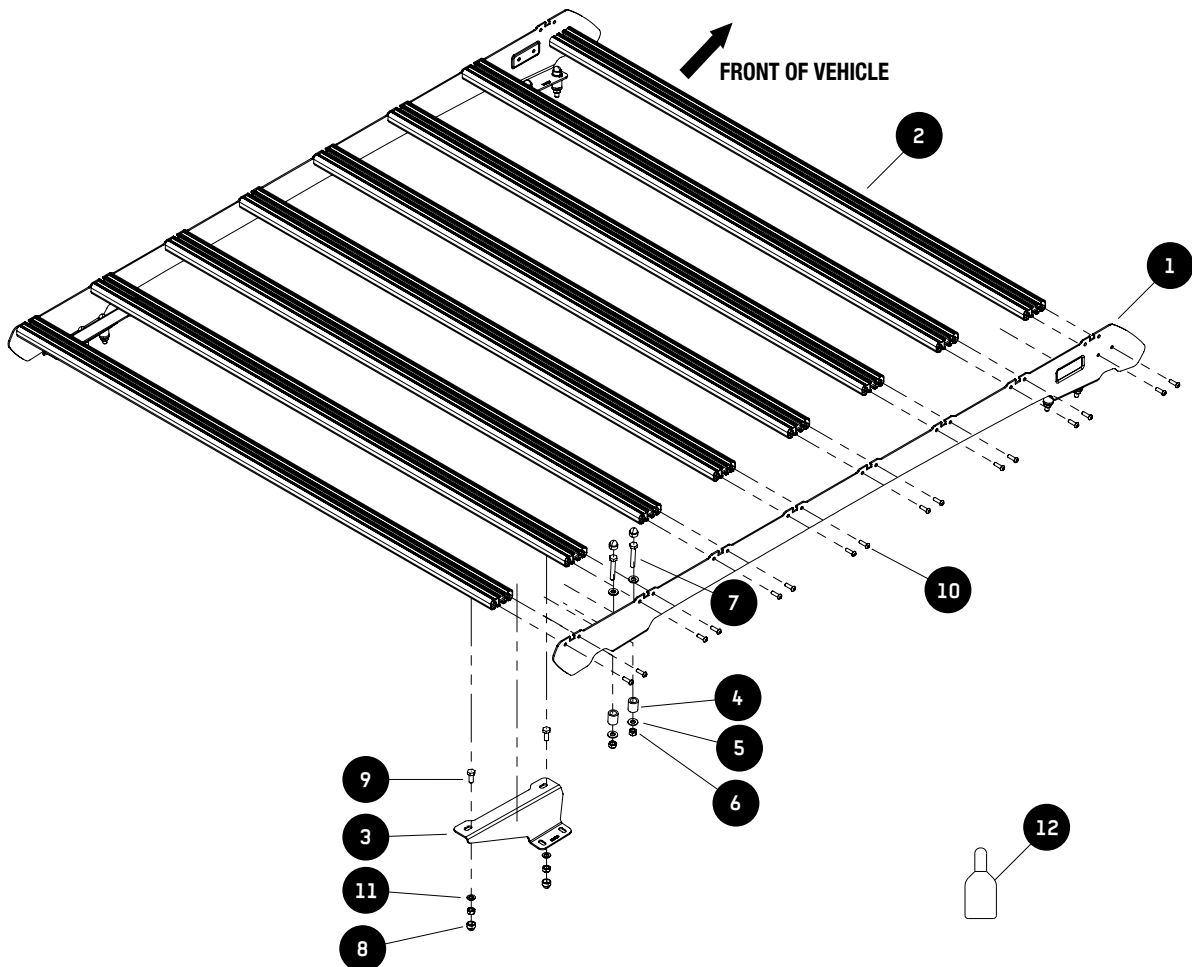

FIGURE 1.1





## HEADLINER REMOVAL





## 2

**HEADLINER REMOVAL**

- 2.1** Start with the sun visors by unclipping the mounting arm cover with a panel tool. Remove the screws and unplug the connector. Keep all hardware and parts together in a safe place.
- 2.2** Remove the visor clip by twisting clockwise until the locking mechanism releases. Repeat on both sides.
- 2.3** Remove the visor light using a panel tool and disconnect the loom. Repeat on both sides.
- 2.4** Remove the A-Pillar handle using a panel tool - from the bottom edge of the cover. Remove the hex bolts and handle. Remove the remaining roof handles in the same manner.
- 2.5** Remove the Sunglass holder by unclipping the cover and unscrewing the screws using a Phillips Head Screw Driver. Remove the console by applying the panel tool to the back and disconnect the loom.
- 2.6** Remove the dome lights and roof speakers (if equipped) using a panel tool and disconnect.
- 2.7** Remove the B pillar handles by unclipping the screw covers to access the fixing screws.
- 2.8** Remove the door seals all around the vehicle.
- 2.9** Remove the A Pillar covers pulling inward and running a panel tool along the pillar to detach from clips. Ensure all clips are removed and in place in the cover.
- 2.10** Remove the upper B-pillar airbag cover and unscrew the fasteners. Using a panel tool, release the clips holding the upper B-Pillar cover in place and remove the fasteners.
- 2.11** Fold down the rear seats and remove the rear wall cover by releasing the top cover first (middle seat belt), then the top trim. Take care with the push clips holding it in place.
- 2.12** Unclip the airbag cover on the C-pillar, in the same manner as Step 2.10 and release the outer edges and clips. Remove the fasteners and clips in the middle.
- 2.13** Remove the last fasteners in the sunglasses holder opening and release the velcro in the front and middle. Slide the liner forward to release the rear clips and velcro.
- 2.14** Remove the factory speaker in the roof to access the fasteners holding the factory roof rail. Repeat on both sides.
- 2.15** Unscrew the fasteners holding the roof rails. Repeat on both sides.
- 2.16** To refit after installation, repeat these steps in reverse.

3

**FIT AND SECURE**

3.1

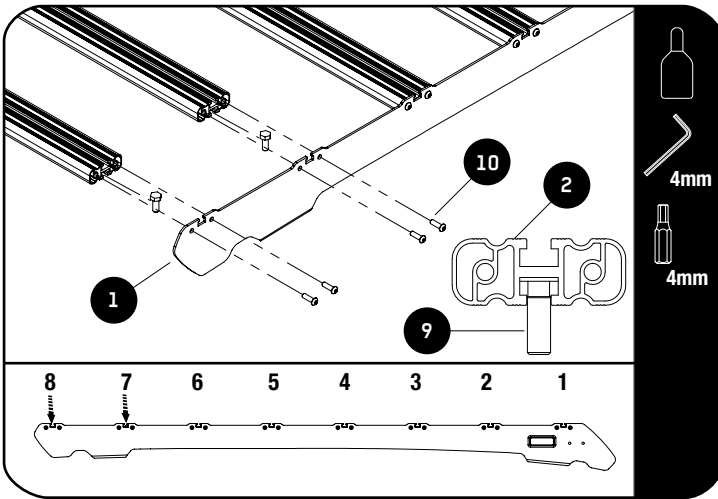

**NOTE: Do not assemble the Front Slat**

**Apply a drop of Thread Locker (Item 12) on each M6 x 20 Button Head Bolt before securing the Slats.**

**Slide two M8 x 20 Hex Bolts (Item 9) into the bottom T-Slots of the slats marked 7 and 8, one on each side.**

**Assemble the Slimsport Slats (Item 2) to the Foot Rails (Item 1), using M6 x 20 Button Head Bolts (Item 10), as shown.**

**Fully tighten.**

**Tightening Torque:**

**M6 : 8-10Nm / 5.9 ft lb - 7.38 ft lb**

3.2

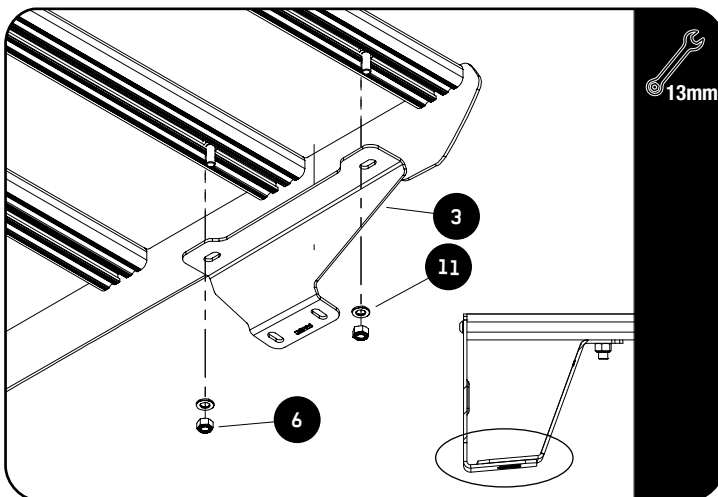

**Loosely assemble the Rear Stiffener Brackets (Item 3) on both sides using the M8 x 16 x 1.6 Flat Washers (Item 11) and M8 x 20 Hex Bolts inserted in Step 3.1 and secure using M8 Nyloc Nuts (Item 6).**

**Do not fully tighten.**

**NOTE: The "foot" of the Strut is fitted on top of the "foot" of the Foot Rail.**

3.3

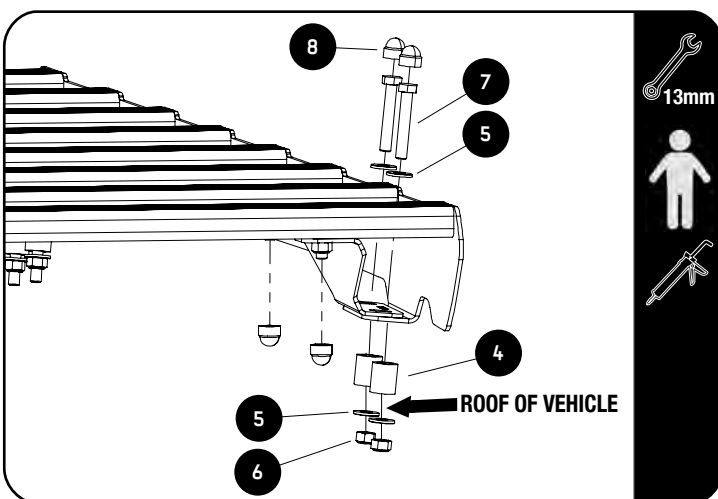

**Position an Aluminium Spacer (Item 4) over each of the factory fixing holes. Fill spacer hole with Sealant.**

**With the help of a friend, lift and position the Slimsport Roof Rack over the roof, aligning with the spacers and OEM Mounting Points.**

**Center the rack and secure using M8 x 19 x 2 Flat Washers, M8 x 50 Hex Bolts and M8 Nyloc Nuts (Items 5, 7 & 6).**

**Fully Tighten all M8 fasteners to the vehicle and slats (Support Struts) and place M8 Nut Caps (Item 8) over all M8 Hex bolts and M8 Nyloc Nuts.**

**Tightening Torque:**

**M8 : 15-20Nm / 11.06 ft lb - 14.75 ft lb**

4

**FIT AND SECURE**

4.1

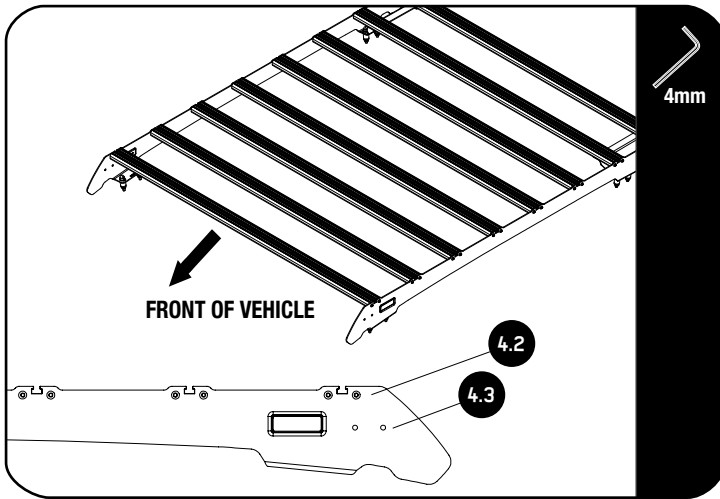

The front slat position is determined by which wind fairing is used. Refer to the fitment guide received with your wind fairing to confirm the correct position.

4.2

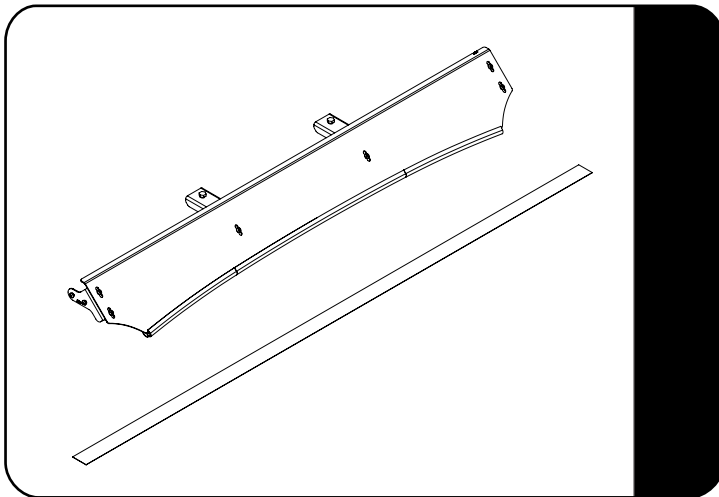

**STANDARD WIND FAIRING ASSEMBLY**



Refer to fitment guide RRAC384.

4.3

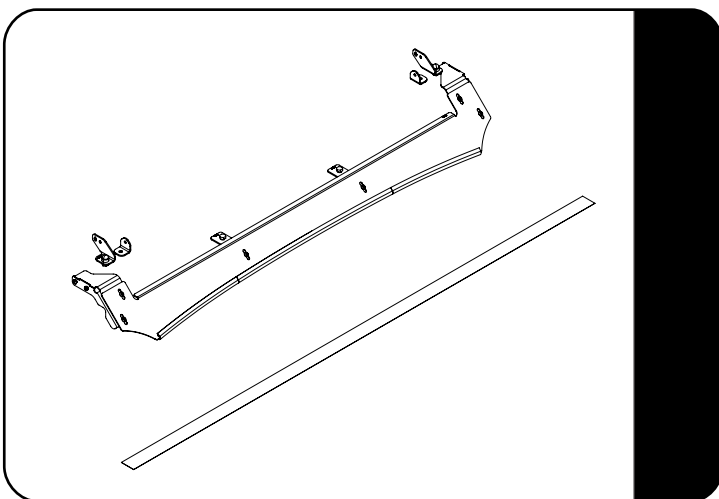

**LIGHT BAR WIND FAIRING ASSEMBLY**



Refer to fitment guide RRAC385.

5

## COMPLETION

5.1

Congratulations! You did it. Take a step back and admire your work!



6

## TAKE A TRIP

After your first trip, check that all nuts, bolts, screws and fittings are tight. Re-tighten where needed. You will find a small amount of settling has happened.

Before going on a trip, check if the nuts, bolts, screws or fittings need to be re-torqued.

7

## INSTALL OTHER VEHICLE AND RACK ACCESSORIES

Now's the time to visit your favorite Front Runner dealer in person or online.

### IMPORTANT!

FRONT RUNNER RACK KITS OFTEN HAVE A HIGHER LOAD RATING THAN THE VEHICLES THEY ARE MOUNTED TO. PLEASE REFER TO YOUR SPECIFIC VEHICLE MANUFACTURER FOR A RECOMMENDED ROOF RATING. FRONT RUNNER CANNOT BE RESPONSIBLE FOR IMPROPER LOADING BEYOND THE VEHICLE MANUFACTURER'S STATED LOAD CAPACITY.

Be sure to tag us. We love to see our gear in action! #FrontRunnerOutfitters

Share your adventures on: 