



RHINO-RACK

RTS520 Holden Colorado RC Crew Cab - Rhino Track Mount
Holden Rodeo RA Crew Cab - Rhino Track Mount
Great Wall V200 - Rhino Track Mount
Great Wall V240 - Rhino Track Mount

Important: Please read these instructions carefully prior to installation.
 Please refer to your fitting instruction to ensure that the cross bars are installed in the correct locations.
 Check the contents of kit before commencing fitment and report any discrepancies.
 Place these instructions in the vehicle's glove box after installation is complete.

Maximum carrying capacity: 100kg.

Layout

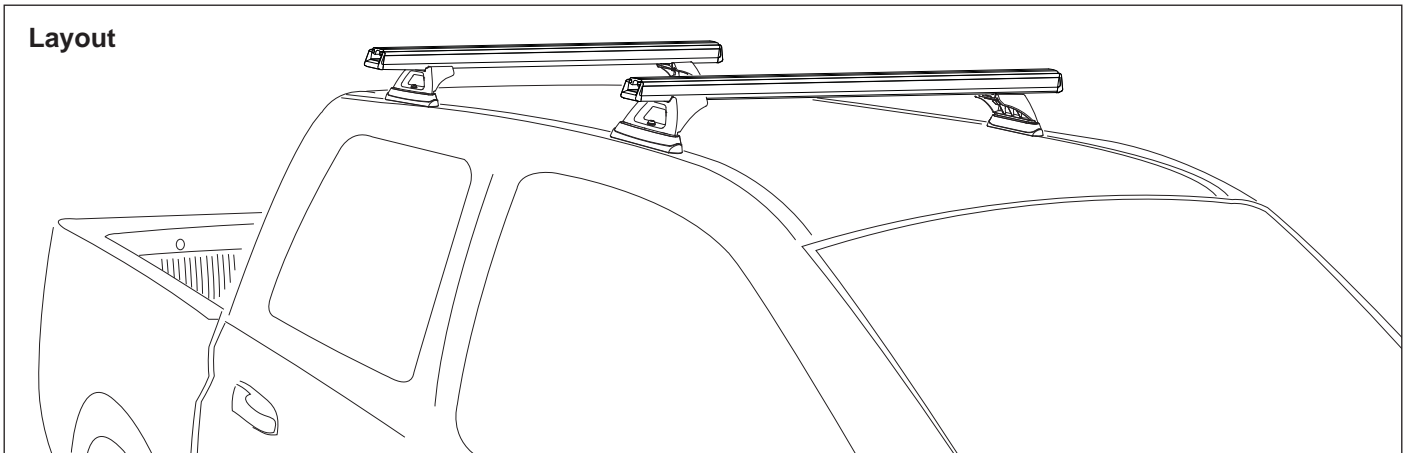

Care Instruction: Wash and clean vehicle roof prior to fitting the tracks and cross bars.

Important Information

Recommendations:

It is essential that all bolt connections be checked after driving a short distance when you first install your cross bars. Bolt connections should be checked again at regular intervals (probably once a week is enough, depending on road conditions, usage, loads and distances travelled). You should also check the cross bars each time they are re-fitted.

Make sure to fasten your load securely. Please ensure that all loads are evenly distributed and that the centre of gravity is kept as low as possible.

Use only non-stretch fastening ropes or straps.

Sensitivity to cross winds, behaviour in curves and braking.

The handling characteristics of the vehicle, changes when you transport a load on the roof. For safety reasons, we recommend you exercise extreme care when transporting wind-resisting loads; special consideration must be taken into account when braking.

Please remove cross bars when putting vehicle through an automatic car wash.

Load Ratings:

Maximum permissible load is 100kg evenly distributed per pair of cross bars (include the weight of the cross bars, 5kg). When cross bars are to be used in unsealed conditions, a safety factor of 1.5 must be applied. That is, for unsealed applications the maximum permissible load is 67kg. Although the cross bars are tested to AS1235-2000, Australian road conditions can be much more rigorous. Please note that increasing the number of cross bars does not increase the vehicles maximum permissible roof load rating.

Note for Dealers and Fitters:

All pages must be taken into consideration when using these instructions.
 It is your responsibility to ensure instructions are given to the end user or client.

Rhino-Rack
 3 Pike Street, Rydalmere,
 NSW 2116, Australia.
 (Ph) (02) 9638 4744
 (Fax) (02) 9638 4822

Document No: RR-189
 Prepared By: Craig Jones
 Authorised By: Gary England

Issue No: 04
 Issue Date: 11/10/2017

These instructions remain the property of Rhino-Rack Australia Pty. Ltd. and may not be used or changed for any other purpose than intended.



RTS520 - Rhino Track Mount

Parts List

Maximum carrying capacity: 100kg.

Item	Component Name	Qty.	Part No.
1	Track End Tab	4	C351
2	Track Extrusion LEFT 1100mm	1	A255
3	Track Extrusion RIGHT 1100mm	1	A255
4	Heavy Duty Buffer Strip 1250mm	2	R003
5	Heavy Duty Cross Bar End Cap	4	M002
6	Heavy Duty Cross Bar 1250mm	2	A019
7	M6 x 40mm Security Screw	4	B085
8	M6 Spring Washer	4	W004
9	M6 x 12.5mm Flat Washer	4	W003
10	RLCP Leg	4	M123
11	RLCP Top Pad	4	M173
12	RLCP Bottom Pad	4	M172
13	M6 Brass Spigot Nut	4	N042K
14	M10 x 20mm Hex Bolt	4	B003
15	M10 Shakeproof Washer	4	W021
16	M10 x 38mm Flat Washer	4	W022
17	M10 Channel Nut	4	N024
18	Stavex Rivet BS 11 4.8mm	14	H060
19	Security Allen Key	1	H021
20	Butyle Patches	15	CA1397
21	Fitting Instruction	1	RR189

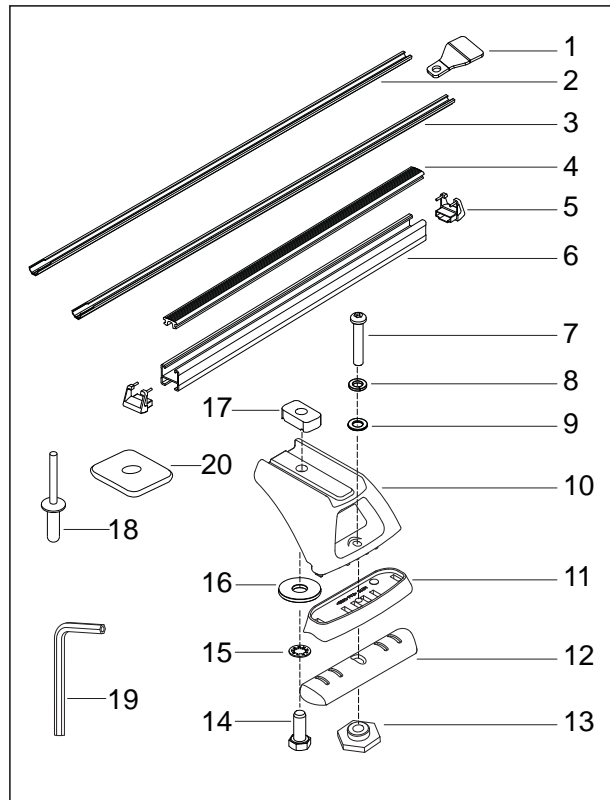

Tools Required:

- | | |
|------------------------------------|--|
| Pneumatic or concertina rivet gun. | Side cutters or Tin snips. |
| Marking pen/pencil. | Selleys Butyl Mastic. |
| Power or Battery Drill. | Caulking Gun. |
| 3 & 5mm drill bit & depth stop. | 5mm Security Allen key, provided in kit. |
| Vacuum cleaner. | Measuring tape. |
| Cold galvanizing solution & brush. | Flat Head screwdriver. |
| Knife (<i>stanley type</i>). | 16mm Spanner. |
| | Plastic Scraper. |



Drill depth stop.

Round piece of wood or plastic of larger outer diameter than the hole being drilled.
5-6 mm hole through centre.

1 Drill through roof trim.

Measure a distance of 215mm from the defined line on the roof trim at the front (*its about 20mm back from the wind-screen rubber*). Drill three holes of diameter 3mm through the trim, it has a steel backing. Measure a further 1105mm from these holes, drill three more holes. **DO NOT DRILL INTO THE ROOF.**

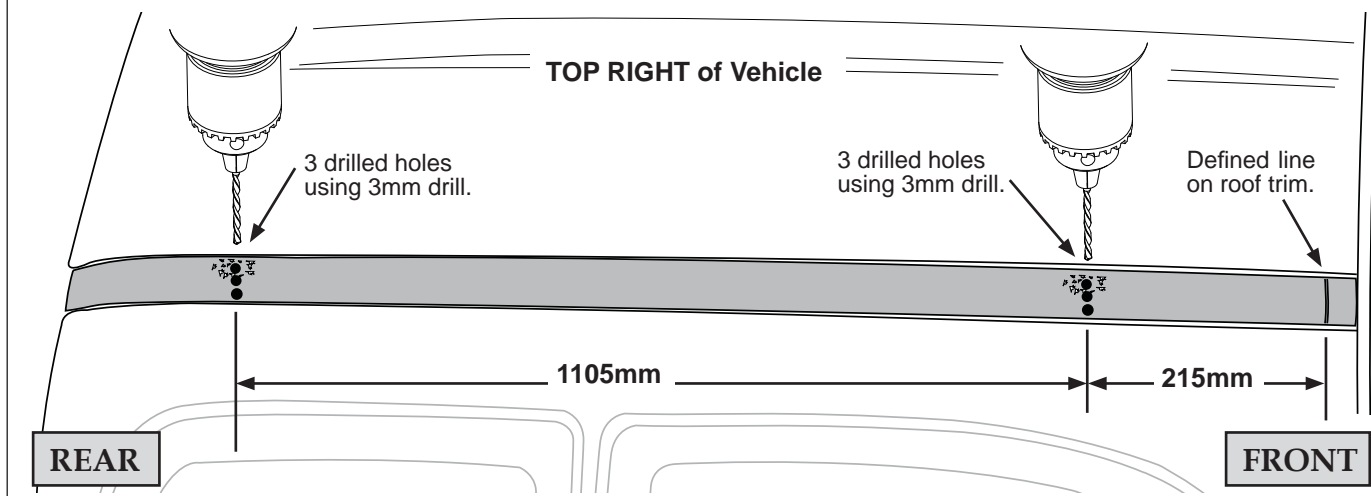



2 Break and remove trim.

a. Stretch and bend the roof trim up in the middle. Slide a blunt instrument under the trim to support it. Cut with side cutters or tin snips. **b.** Support the roof trim at the drilled holes. Bend the trim back and forth to break at the drilled holes.

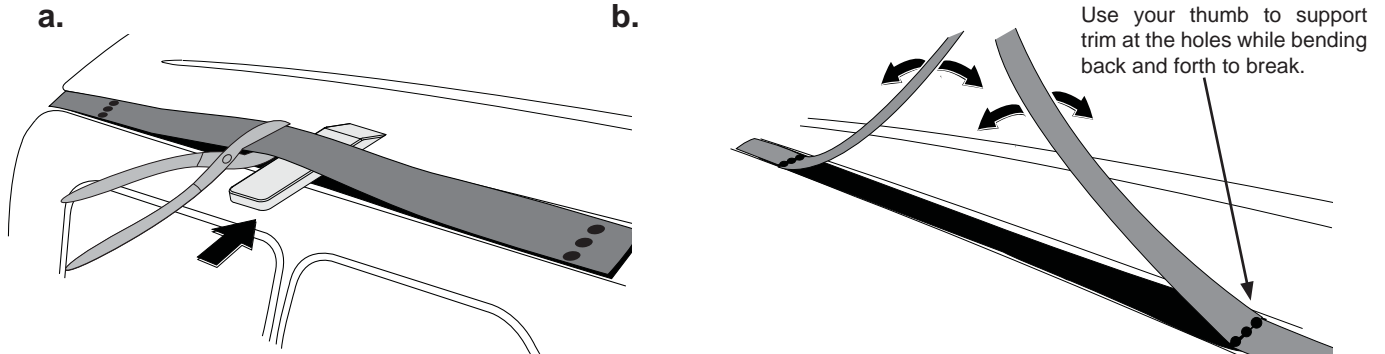

3 Remove rubber strip.

a. Use a knife to cut the rubber strip level with the edges of the remaining roof trim. Pull rubber strip out of the roof channel. **b. The grey sticky foam left behind must be fully scraped off before the tracks can be installed.** Use a plastic scraper and non petroleum solvent such as Cleansol to help remove. The roof channel must be totally clean before proceeding any further.

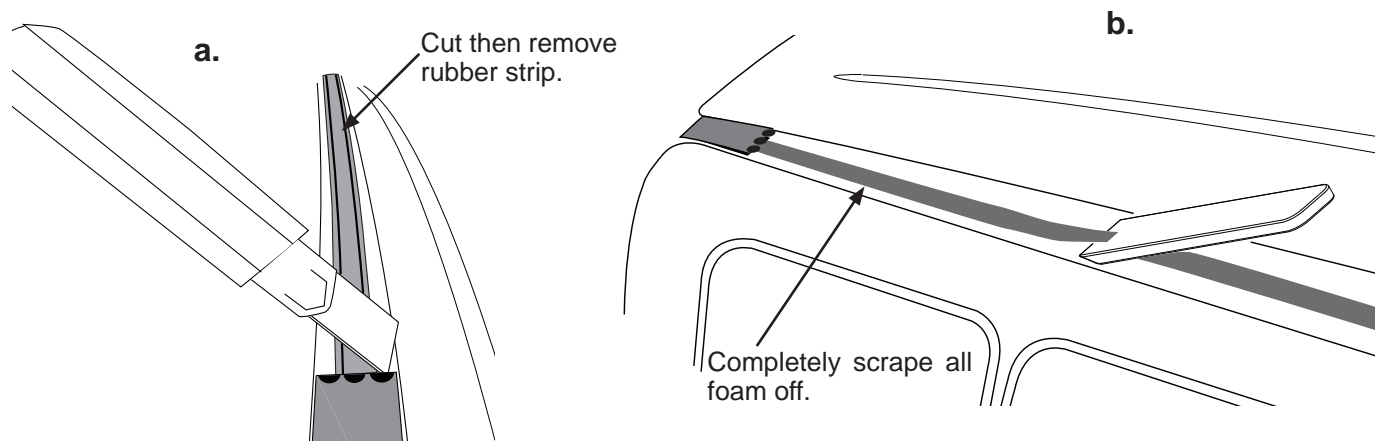

4 Tracks.

Track extrusions are **LEFT** (passenger side) and **RIGHT** (driver side) handed.

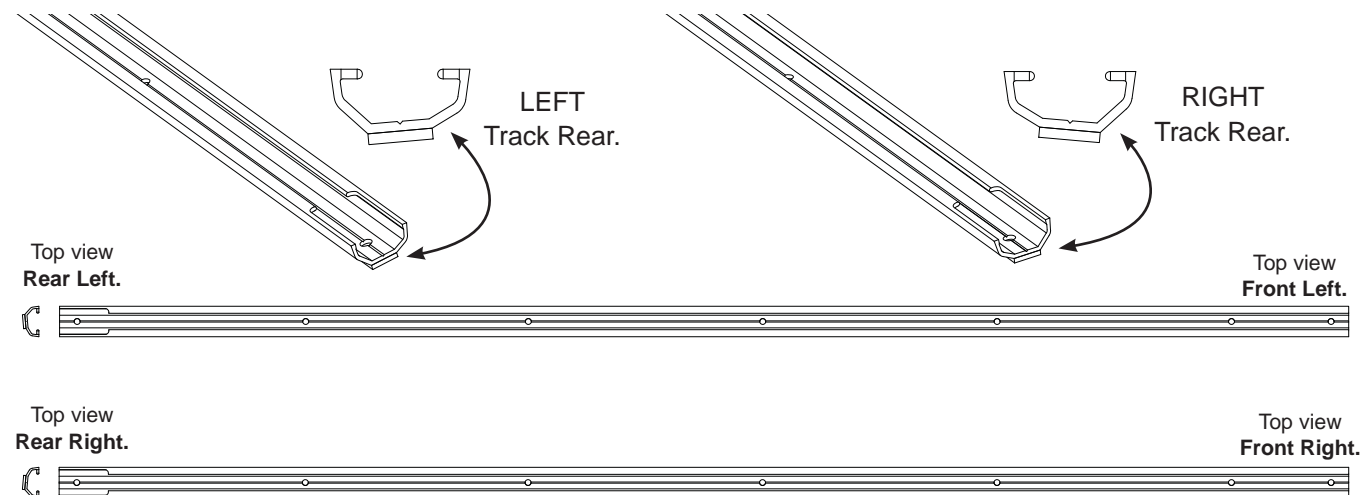



RTS520 - Rhino Track Mount

5 Correctly position track.

Locate track in roof channel. Screw an M6 brass hex nut and M6 screw together. Slide screw and brass hex nut in from slot at rear of track. Slide along track extrusion to check the angle. Look end on to make sure the track is sitting properly in the roof channel. The screw should be close to vertical when the track is in the correct position.

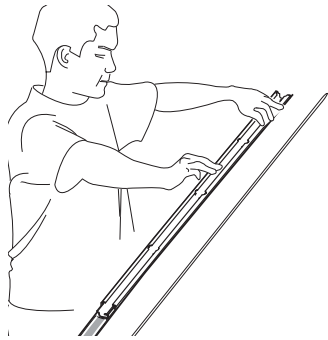

← Outside of vehicle.

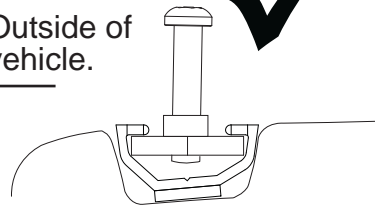

Correct

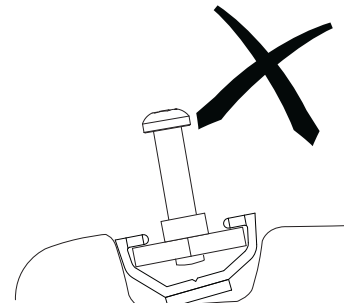

Incorrect

6

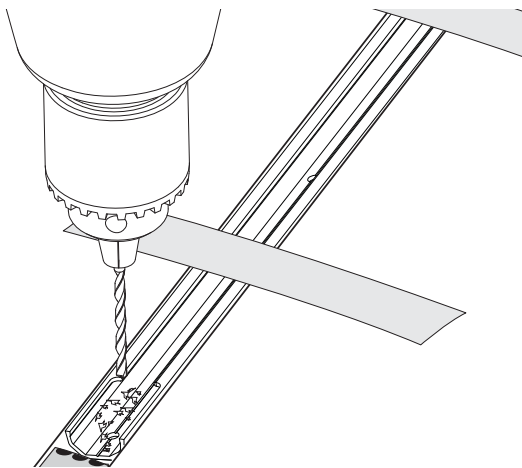

Spot drill for holes.

Hold the track in place while the holes are marked out. Masking tape can be used to hold track. Use a 5mm drill bit to spot drill through each of the holes in the track. Start at the rear and work forward while maintaining spot drill mark alignment.

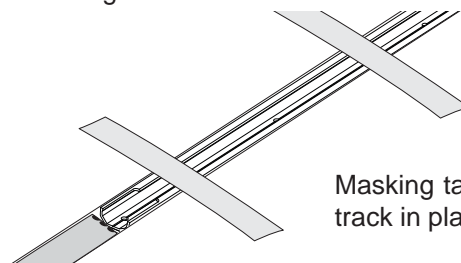

Masking tape to hold track in place.

7

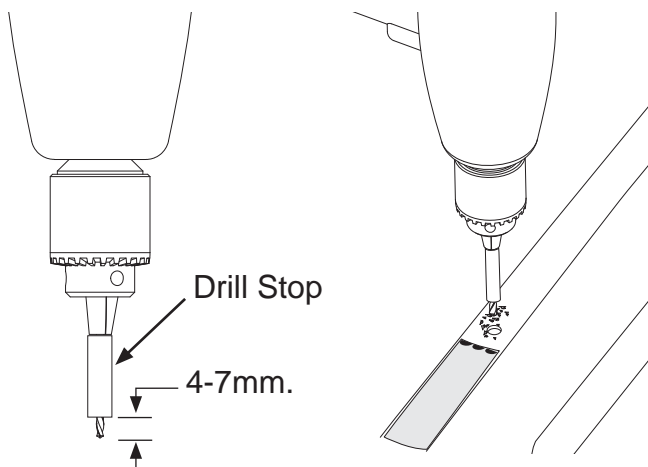

Drill through.

Remove the track. Marked holes can now be drilled through the roof skin using a 5mm drill bit. **A DRILL STOP MUST BE USED** to avoid penetrating the inside hood lining.

8

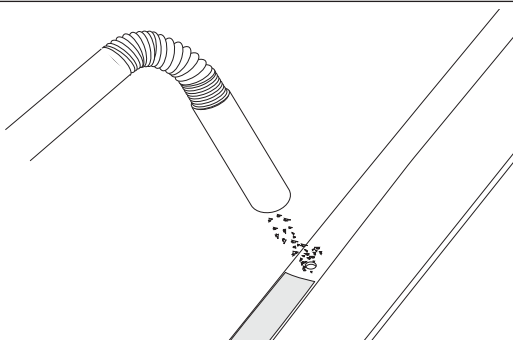

Vacuum swarf.

Swarf must be vacuumed from roof to avoid rust spots and scratching. Carefully wipe with a clean rag to remove any excess.

DO NOT USE AN AIR GUN to blow swarf as it will get trapped under the remaining roof trim.



RTS520 - Rhino Track Mount

9a Apply sealer.

STEP 1. Apply a liberal amount of cold galvanizing solution to the inside and surrounds of all holes. Allow cold galvanizing solution to touch dry, ten minutes or so, **STEP 2.** Apply a liberal amount of Selleys Butyl Mastic sealer in each hole.

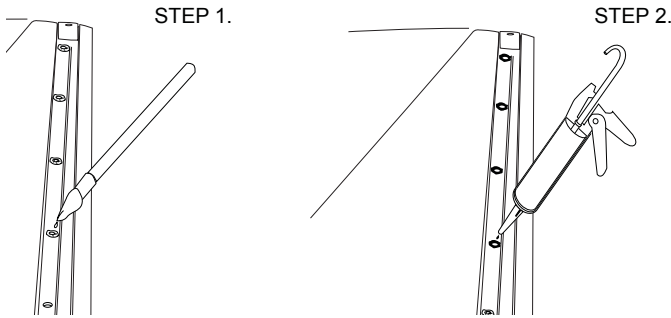

9b

1: Remove the backing tape from the Butyl Patches.
2: Place over holes drilled. Once in place remove the rest of the protective tape from the top of the patches.

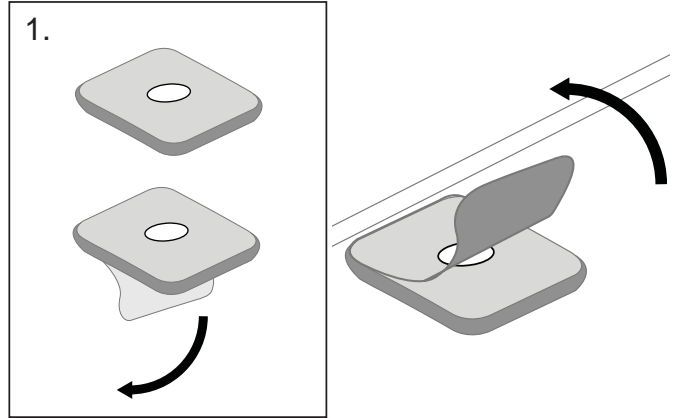

10

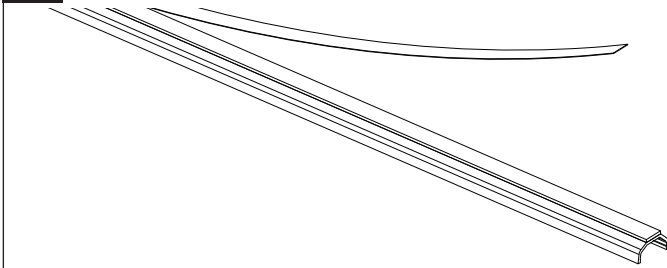

Backing tape.

Completely remove white backing tape from each track extrusion.

11 Fasten Track.

Accurately place the track over the drilled holes in the roof channel using the rivets to position. **Make sure track orientation is correct, (refer to step 4).** Place the metal track end tabs at the end of each track. Secure end tab with rivet. Using either a pneumatic or concertina type rivet gun, rivet the track into place. Push down with pressure while popping rivets to make sure they are all firmly seated onto the base of the track.

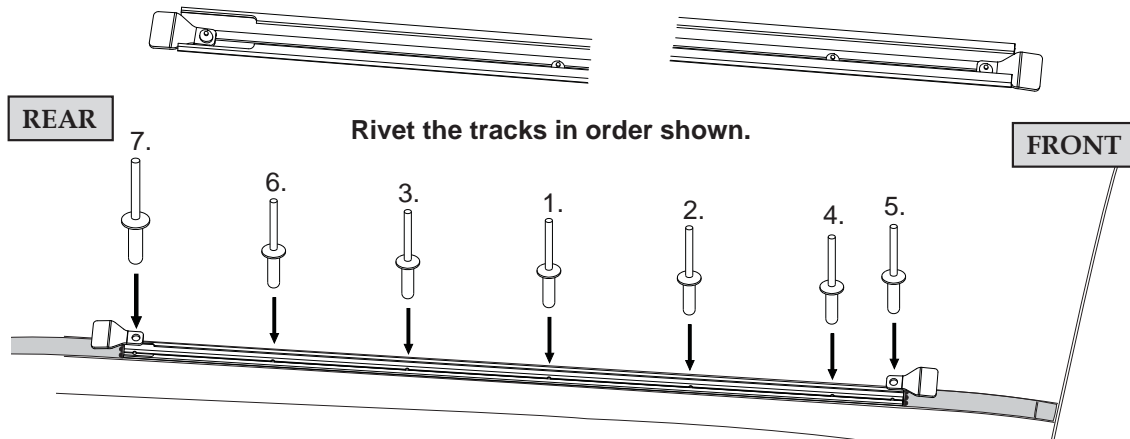

12

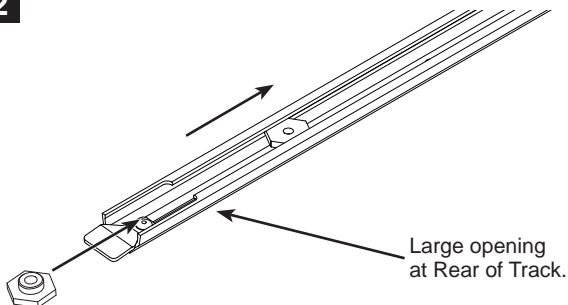

Brass hex nuts.

Insert two brass hex nuts per track. Slide brass nuts to desired position using the large slot at rear of track. As a guide position the M6 hex nuts 700-750mm apart as this is a common spacing.



RTS520 - Rhino Track Mount

13

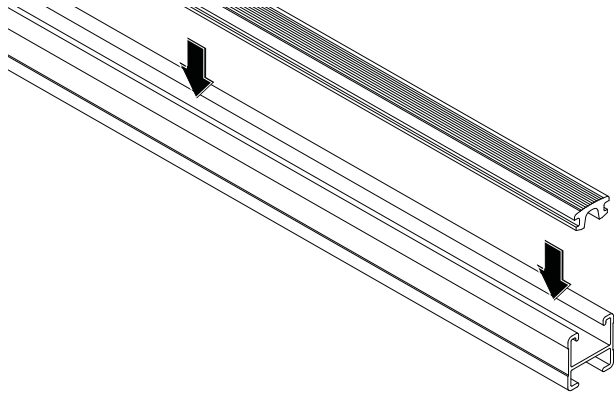

Insert cross bar rubber.

Insert the cross bar rubber into the top of the cross bar. The rubber may need to be trimmed level with end of the cross bar.

14 Legs & cross bars.

Place each leg assembly over the brass hex nut in the track. Insert the M6 security screw and washers through the hole in the leg as shown and screw into the brass hex nut. Make sure the legs are parallel with the opposing side. As a guide position the legs 700-750mm apart as this is a common spacing for accessories.

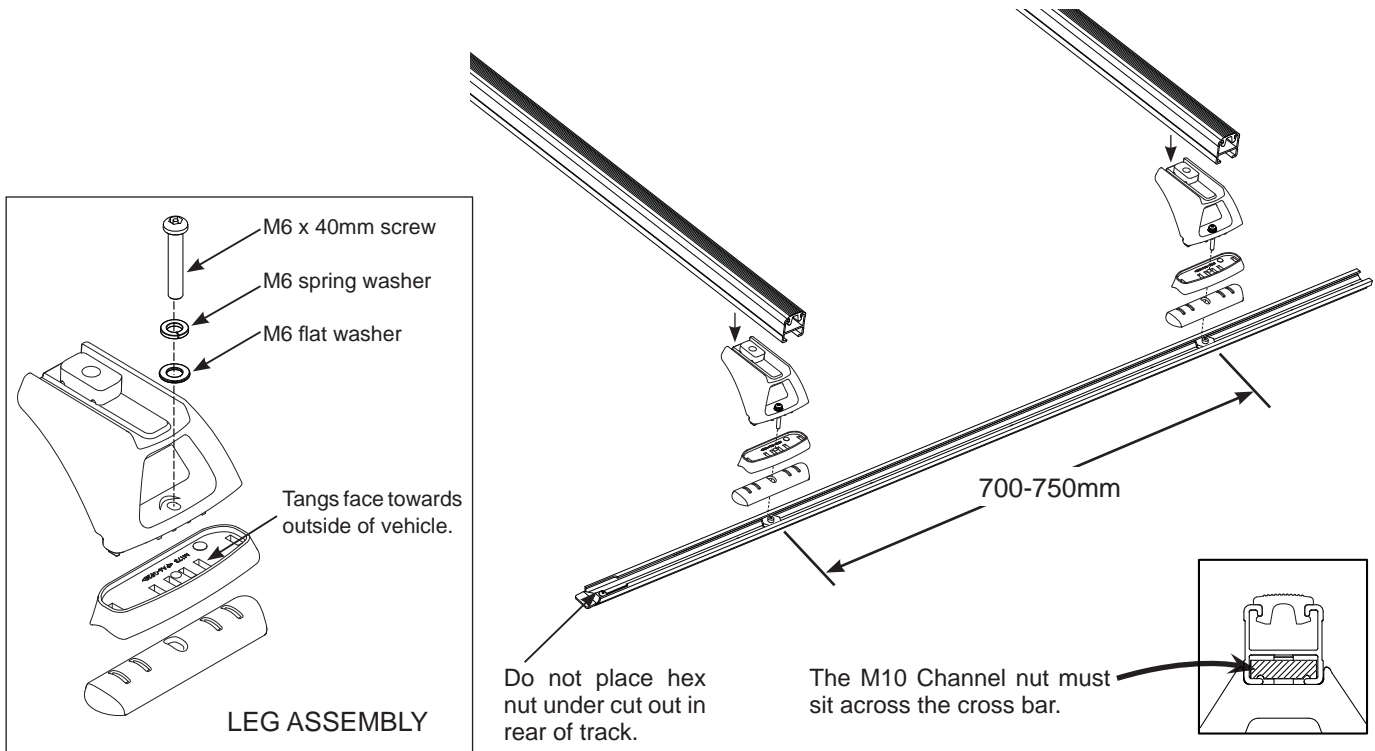

15

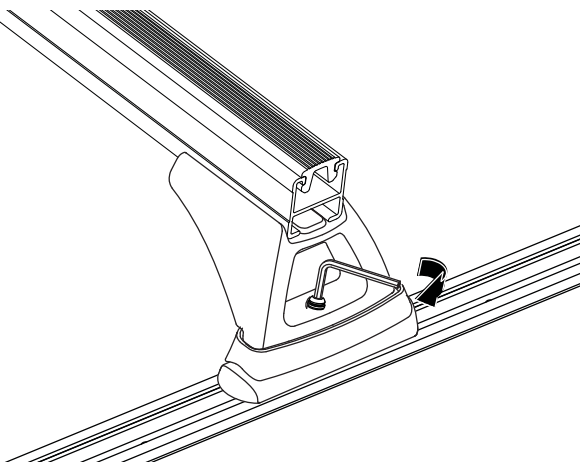

Tighten M6 screws.

Slide the cross bar to give better access to M6 screw. Progressively and evenly tighten both the left and right side leg screws to secure the leg and pads to the track.

Tighten the M6 screws to 3-4 Nm.

Do not over tighten.



16 Equal overhang.

Measure to make sure the cross bar overhang is equal on both sides.

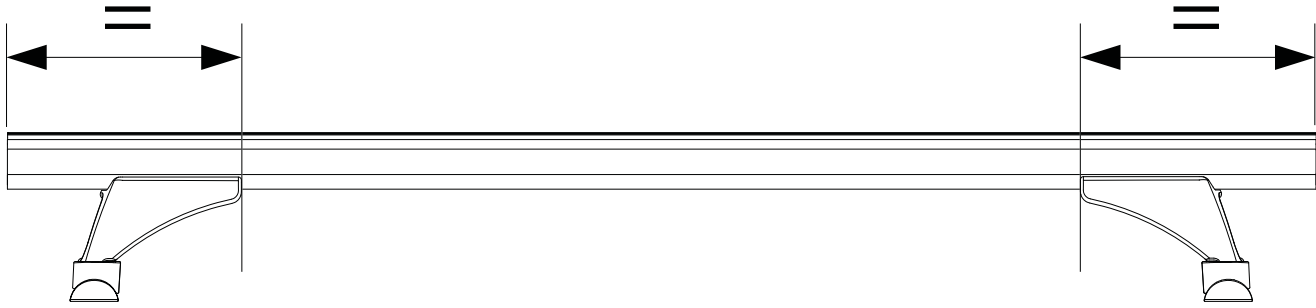

17

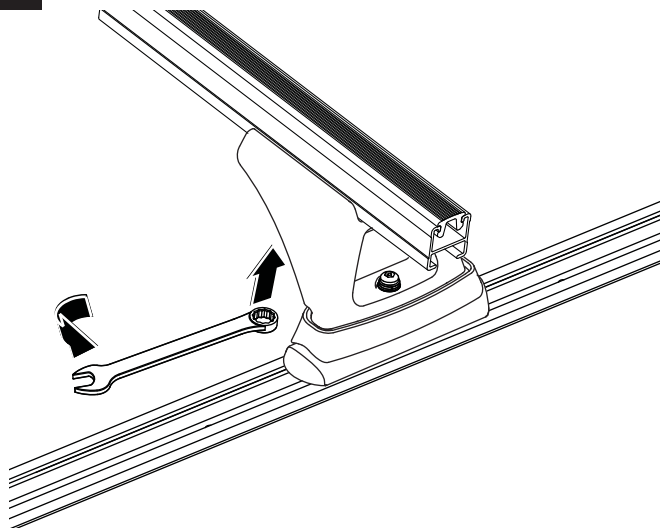

Tighten M10 bolts.

Check that all four channel nuts are fully located across the cross bar before and after tightening.
Tighten the M10 cross bar attachment bolts using a 16mm spanner.
Tighten to 4-5 Nm. Do not over tighten.

The M10 Channel nut must sit across the cross bar when tight as shown.

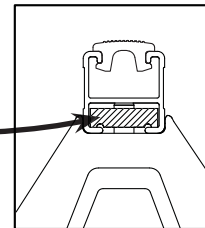

18

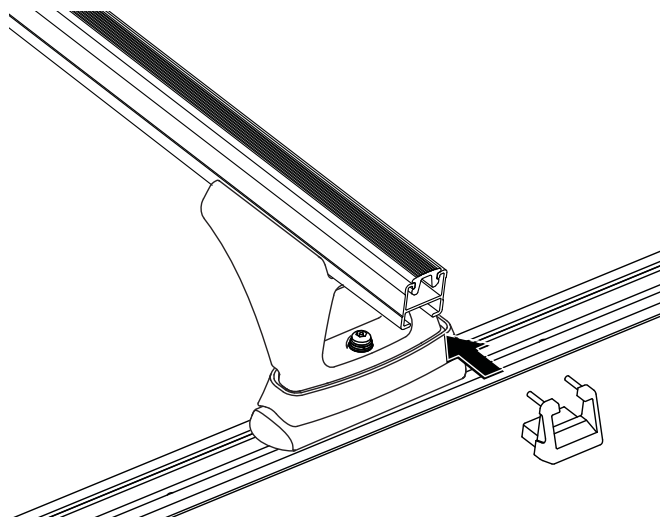

Fit end caps.

Insert the four end caps into ends of the cross bars. A rubber mallet may be needed to knock them in.

Check all attachment bolts and screws after fitment.