



FRONT RUNNER LED 40" LIGHT BAR BRACKETS

ENG

RRAC099/RRAC101

 INSTALL TIME: 30 mins

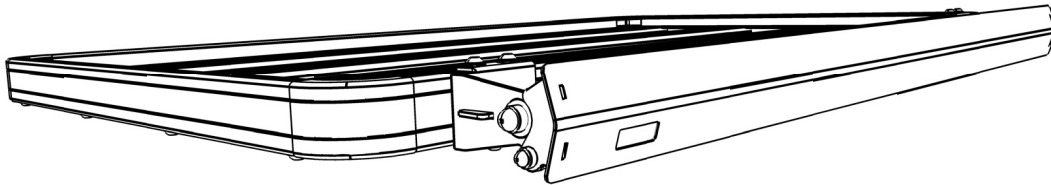

Front Mount

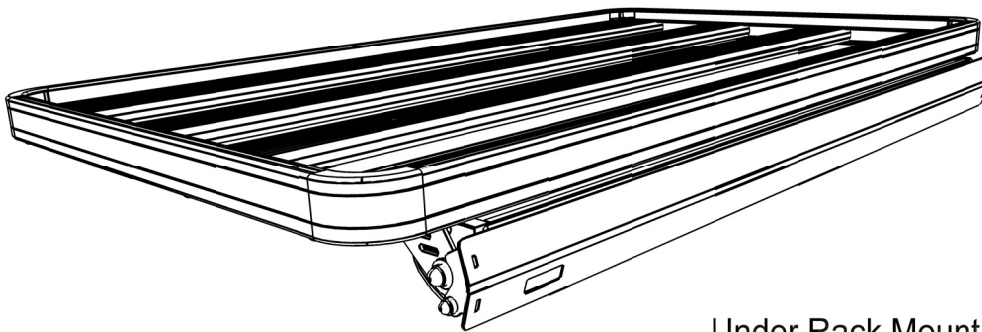

Under Rack Mount



If you would like to mount your Light Bar under your Rack, refer to Sections 3 and 4. You will need a minimum of 90 mm clearance between the bottom of the Rack and the vehicle's roof in order to fit the LED Light Bar and Cover.

If you would like to mount your Light Bar in front of your Rack, refer to Sections 1 and 2.

IMPORTANT WARNING!

IT IS CRITICAL THAT ALL FRONT RUNNER PRODUCTS BE PROPERLY AND SECURELY ASSEMBLED AND ATTACHED TO YOUR VEHICLE. IMPROPER ATTACHMENT COULD RESULT IN AN AUTOMOBILE ACCIDENT, AND COULD CAUSE SERIOUS BODILY INJURY OR DEATH TO YOU OR TO OTHERS. YOU ARE RESPONSIBLE FOR ASSEMBLING AND SECURING ALL FRONT RUNNER PRODUCTS TO YOUR VEHICLE, CHECKING THE ATTACHMENTS PRIOR TO USE, AND PERIODICALLY INSPECTING THE PRODUCTS FOR ADJUSTMENT, WEAR, AND DAMAGE. THEREFORE, YOU MUST READ AND UNDERSTAND ALL OF THE INSTRUCTIONS AND CAUTIONS SUPPLIED WITH YOUR FRONT RUNNER PRODUCT PRIOR TO INSTALLATION OR USE. IF YOU DO NOT UNDERSTAND ALL OF THE INSTRUCTIONS AND CAUTIONS, OR IF YOU HAVE NO MECHANICAL EXPERIENCE AND ARE NOT THOROUGHLY FAMILIAR WITH THE INSTALLATION PROCEDURES, YOU SHOULD HAVE THE PRODUCT INSTALLED BY A PROFESSIONAL INSTALLER OR OTHER QUALIFIED PERSONNEL.

1 GET ORGANIZED - FRONT MOUNT INSTALLATION

Here is what you are looking at:

Item #	Quantity	Description
1	6	M8x20 BUTTON HEAD BOLT
2	1	FRONT COVER
3	2	FRONT RACK BRACKET
4	8	M8 FLAT WASHER
5	6	M8 NYLOC HEX NUT
6	2	M8x24.5x3 FLAT WASHER
7	2	M8 SPRING WASHER
8	2	M8x25 HEX BOLT
9	2	M8 NUT CAP
10	2	M6 NUT CAP
11	2	M6 NYLOC HEX NUT
12	4	M6 FLAT WASHER
13	2	M8x19x2 FLAT WASHER
14	1	40 INCH LED LIGHT BAR (Supplied with RRAC101)

You will need:

- 10 mm Flat or Socket Wrench
- 13 mm Flat or Socket Wrench
- 4mm and 5 mm Hex Key
- Measuring Tape

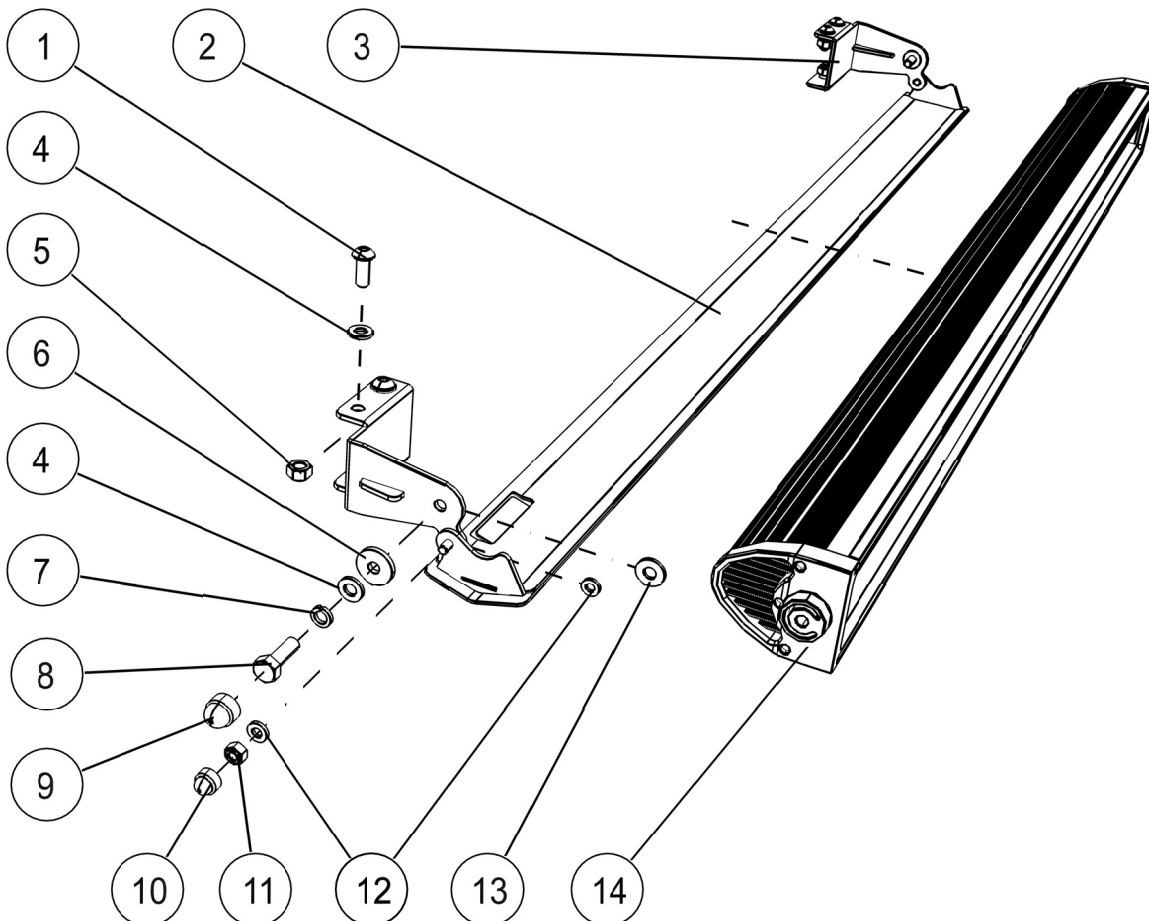

(A) Familiarize yourself with the parts and then step away from the work area and read through these instructions from beginning to end. Take a moment as a little prep now may save you a lot of time later.

2 INSTALL LIGHT BAR - FRONT MOUNT

- (A)** Start with removing the front right hand side Corner Piece with a 4mm Hex Key.



- (B)** Slide the left Hand Front Mounting Bracket (Item 3) with three M8 x 20 Button Head Bolts, three M8 Flat Washers and three Nyloc assembled as per picture. (Items 1, 4 & 5)

Make sure that the tab for the Light Cover, points downward as indicated in the image.



- (C)** Repeat Step 2A for the right hand side Front Mounting Bracket. Loosely fasten the two Front Brackets to the front slat of the Rack as shown.



- (D)** Fasten the Front Cover (Item 2) to the two Mounting Brackets using the four M6 Flat Washers and two M6 Nyloc Nuts (Items 11 & 12). The Front Cover should still be able to rotate after fastening, but should not open on it's own.

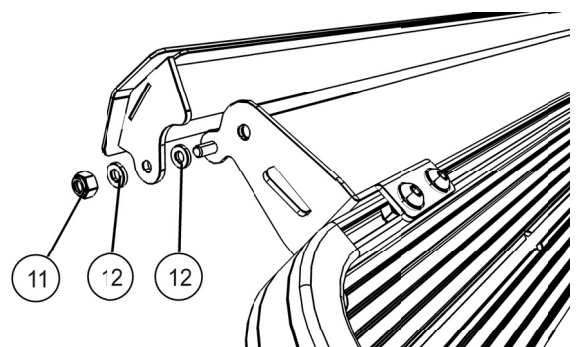

2 INSTALL LIGHT BAR - FRONT MOUNT CONT...

- (E)** Secure the Light Bar (Item 6) onto the Mounting Brackets as shown using the two M8 x 19 x 2 Flat washers M8 x 24.5 Flat Washers, two M8 Flat Washers, two M8 Spring Washers and two M8 x 20 Hex Bolts (Items 13, 6, 4, 7 & 8)

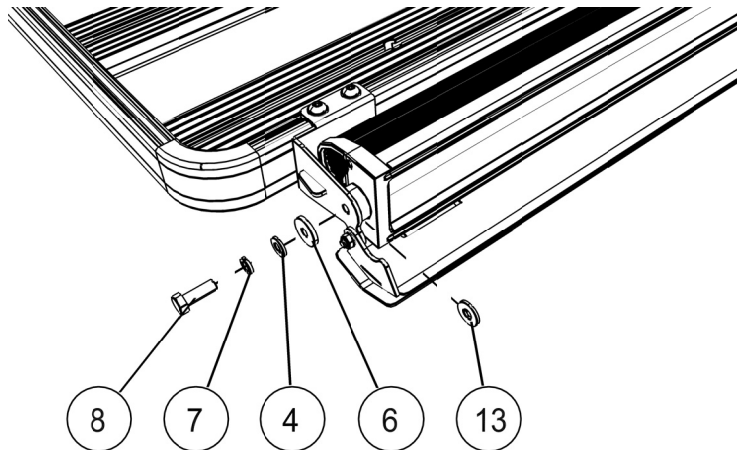

- (F)** Using a tape measure. Center the Mounting Brackets, Cover Assembly and Light Bar from left to right and fasten the six Button Head Bolts mentioned in Step 2B and 2C with a 5mm Hex Key.

- (G)** Place a M6 Nut Cap (Item 10) over each of the M6 Nyloc Nuts from Step 2E. Place a M8 Nut Cap (Item 9) over each of the M8 Nyloc Nuts from Step 2B and 2C.

Wire the Light Bar to the vehicle according to your personal preference or seek assistance from an auto electrician.



- (H)** Congratulations, you have completed your installation. Take a step back and admire your work. Good Job!

3 GET ORGANIZED - UNDER RACK INSTALLATION

Here is what you are looking at:

Item #	Quantity	Description
1	4	M8x20 HEX BOLT
2	2	MOUNTING BRACKET
3	4	M8 FLAT WASHER
4	4	M8 NYLOC HEX NUT
5	6	M8 NUT CAP
6	1	FRONT COVER
7	2	M8x24.5 FLAT WASHER
8	2	M8 SPRING WASHER
9	2	M8x25 HEX BOLT
10	2	M6 NUT CAP
11	2	M6 NYLOC HEX NUT
12	4	M6 FLAT WASHER
13	2	M8x19x2 FLAT WASHER
14	1	LED LIGHT BAR (Supplied with RRAC101)

You will need:

10 mm Flat or Socket Wrench
 13 mm Flat or Socket Wrench
 Measuring Tape

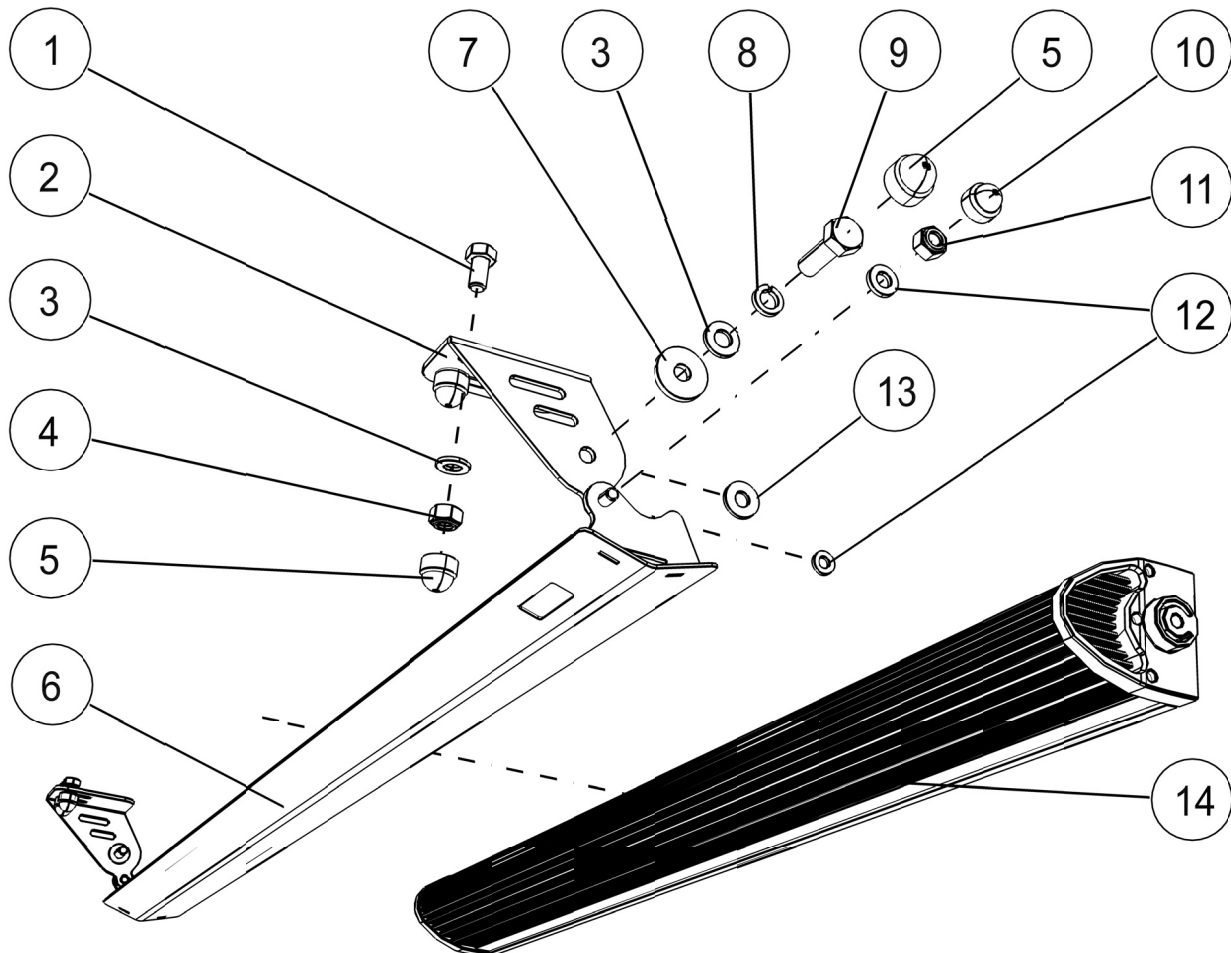

(A) Familiarize yourself with the parts and then step away from the work area and read through these instructions from beginning to end. Take a moment as a little prep now may save you a lot of time later.

4 INSTALL LIGHT BAR- UNDER RACK

- (A)** Loosen and remove the Wind Deflector from your Rack if it is already fitted. Working underneath the Rack, insert two M8 x 20 Hex Bolts (Item 1) into each end of the front slat using the machined slots as shown.

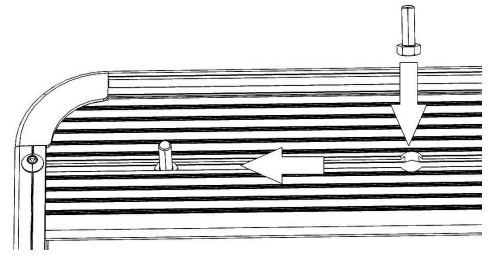

- (B)** Loosely fasten the two Mounting Brackets (Item 2) to the front slat of the Rack as shown, using the four M8 x 20 Hex Bolts inserted in Step 4A, four M8 Flat Washers and four M8 Nyloc Nuts (Items 3 & 4).

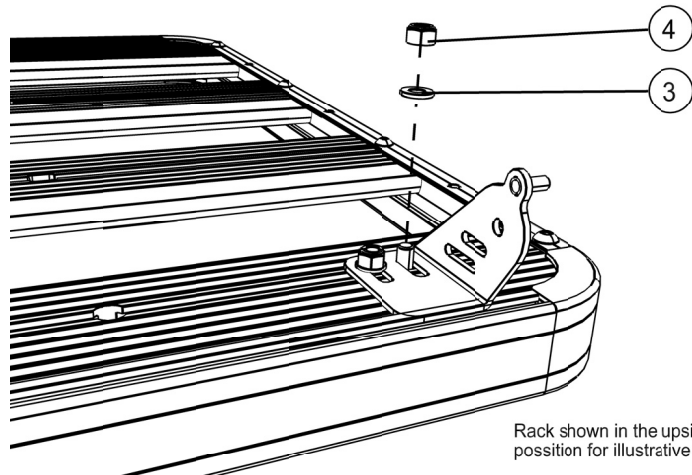

- (C)** Fasten the Front Cover (Item 7) to the two Mounting Brackets using the four M6 Flat Washers, and two M6 Nyloc Nuts (Items 11 & 12). The Front Cover should still be able to rotate after fastening.

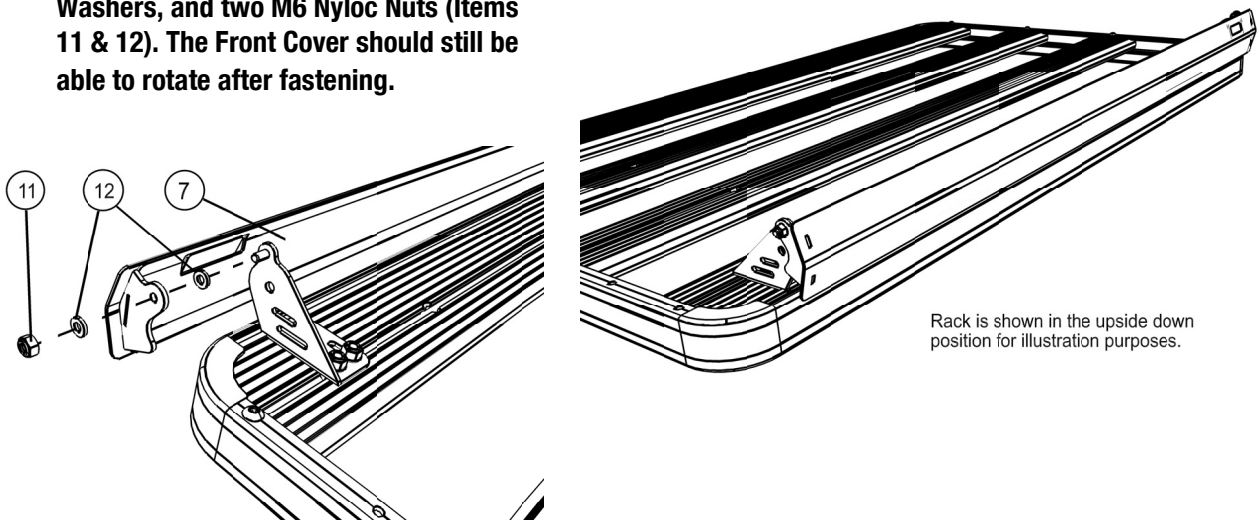

- (D)** Using a tape measure, center the Mounting Bracket and Cover Assembly from left to right and fasten the four Nyloc Nuts from Step 4B.

4 INSTALL LIGHT BAR - UNDER RACK CONT...

- (E)** Secure the Light Bar (Item 14) onto the Mounting Brackets as below using the two M8 x 19 x 2 Flat washers, two M8 x 24.5 Flat Washers, two M8 Flat washers, two M8 Spring Washers and two M8 x 20 Hex Bolts (Items 13, 7, 3, 8 & 9)

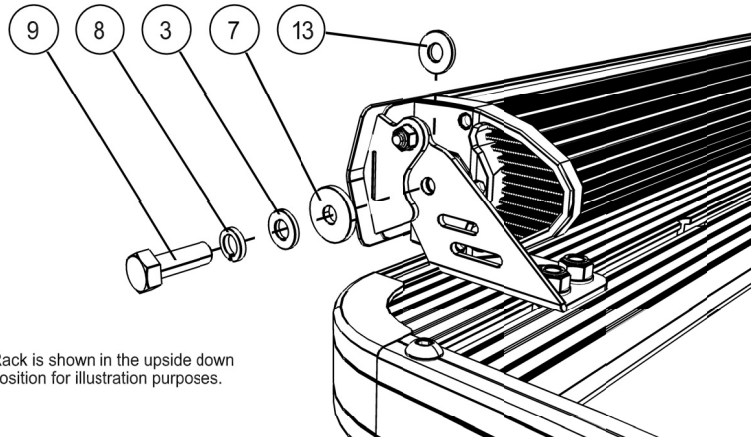

- (F)** Place a M6 Nut Cap (Item 10) over each of the M6 Nyloc Nuts from Step 4D. Place a M8 Nut Cap (Item 5) over each of the M8 Nyloc Nuts from Step 4B and the M8 x 20 Hex Bolts from Step 4E.

Wire the Light Bar to the vehicle according to your personal preference or seek assistance from an auto electrician.

- (G)** Congratulations, you have completed your installation. Take a step back and admire your work. Good Job!

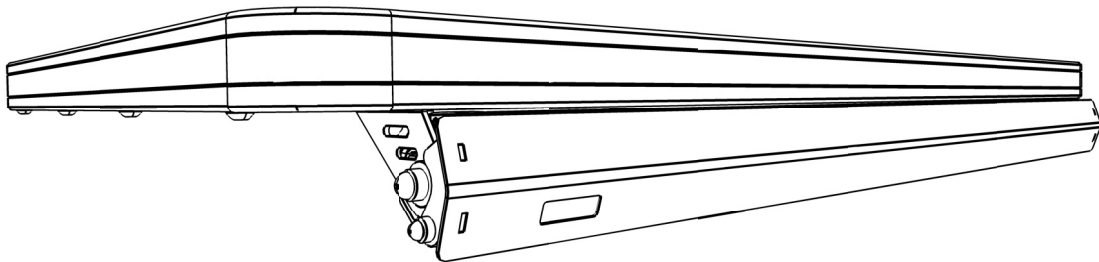

5 INSTALL OTHER VEHICLE AND RACK ACCESSORIES

- (A)** Now's the time to visit your favourite Front Runner dealer in person or online.