

 **MISUTONIDA**
  *italian style* **4x4**
accessories

FORD RANGER



Item Code

Codice Articolo

Référence Article

: RLL/2204/IX

GB

STAINLESS STEEL
ROLL BAR LINE 2 PIPES

ITA

ROLL BAR LINE IN ACCIAIO INOX
2 TUBI

FR

ROLL BAR LINE
EN ACCIER INOX 2 TUBES

FORD RANGER

Part List	
Lista della bulloneria	
Liste des pièces	
A	T S C E I 10X35 x 4
B	VIPLA Ø63 Plastic Plastica Plastique x 4
C	Ø 6 x 8
D	TBCEI 8X20 x 8
E	MIT 63 x 4

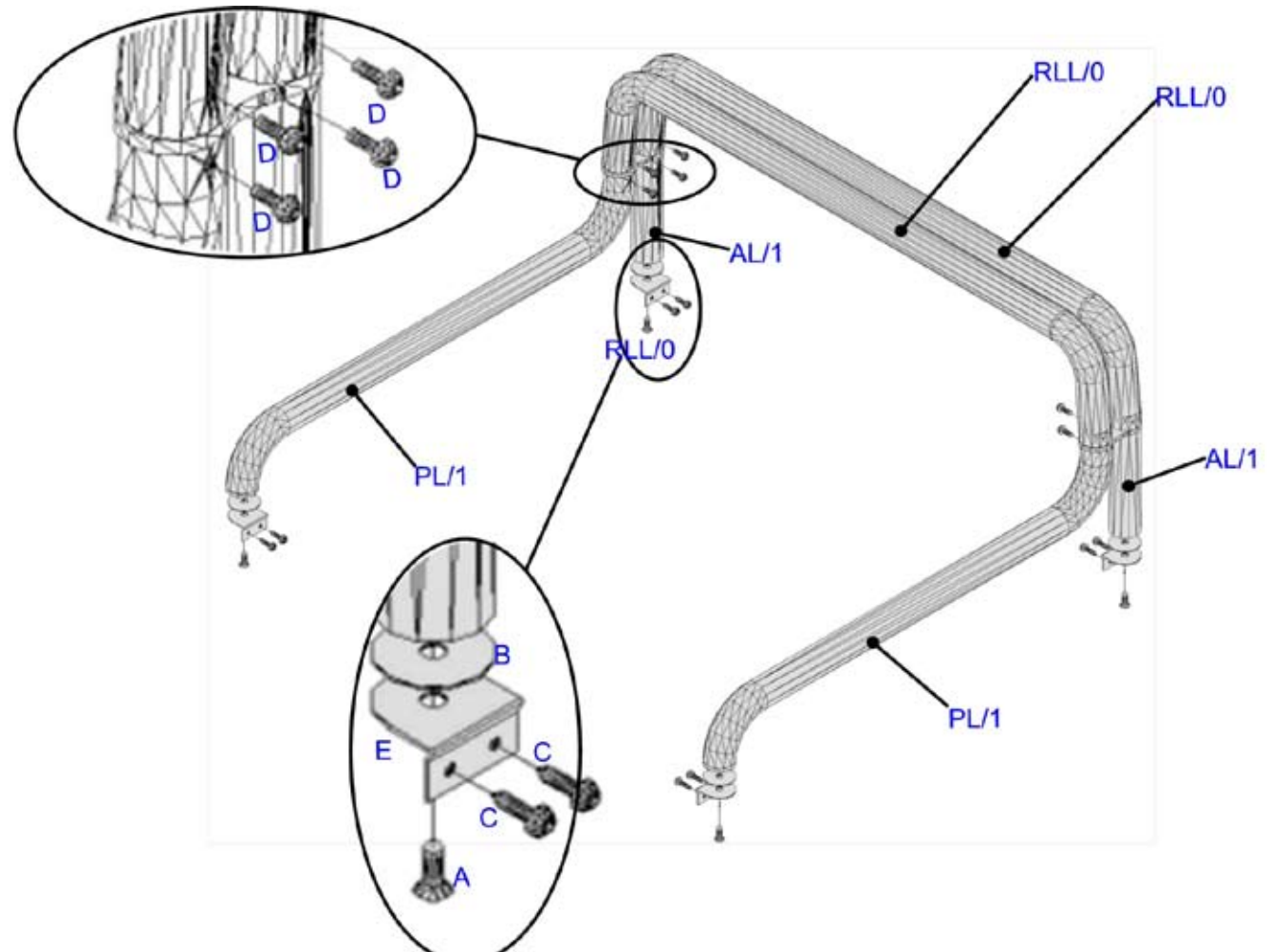

MISUTONIDA
 italian style accessories **4x4**

GB

FITTING INSTRUCTIONS

1. Assemble together the pipes that create the front part of the roll bar (n.2 AL1 and n.1 AL2).
2. Assemble together the pipes that create the rear part of the roll bar (n.2 PL1 and n.1 AL2).
3. Fix the E brackets on the roll bar using A and B.
4. Position the roll bar on the tonneau edges and drill in correspondence of the holes in E brackets, fix it to the tonneau using C.
5. Tighten all the set of bolts.

ITA

ISTRUZIONI DI MONTAGGIO

1. Montare insieme i tubi che compongono la parte anteriore del roll bar (n.2 AL1 con AL2)
2. Montare insieme i tubi che compongono la parte posteriore del roll bar (n.2 PL1 e AL2).
3. Fissare le staffe E sul roll bar utilizzando A e B.
4. Posizionare il roll bar sulle sponde del cassone e bucare in corrispondenza dei fori su E, fissandolo al cassone tramite C.
5. Serrare tutta la bulloneria.

FR

INSTRUCTIONS DE MONTAGE

1. Monter ensemble les tubes qui forment la partie anterieure du roll bar (n.2 AL1 et n. 1 AL2).
2. Monter ensemble les tubes qui forment la partie posterieure du roll bar (n.2 PL1 et n. 1 AL2).
3. Fixer les ètriers E sûr le roll bar en utilisant A et B.
4. Positionner le roll bar sûr le bord de la benne et forer en correspondance des trous sûr E, fizex le roll bar avec C.
5. Serrer toute la boulonnerie.

Date Data Date	Item Code Cod.Articolo Réf. Article	Vehicle model Modello Veicolo Modèle de Voiture
08/06/07	RLL/2204/IX	FORD RANGER

Checked and approved by
Controllato ed approvato da
Controlé et approuvé par

**Claudio
Gallo**

 **MISUTONIDA**
italian style accessories **4x4**