



START HERE!

READ ME FIRST

Don't be a hero and muscle through this installation without reading these fitting instructions first! Improper installation of this gear may void certain aspects of your warranty.

Before you begin, take a moment and open all your Front Runner rack kit boxes and gather the assembly instructions for the various components.

A complete kit will contain:

1. A Front Runner Mounting System specific to your vehicle
2. A Front Runner Rack Tray or Load Bar Slats

This document will guide you through the assembly of the mounting system and assist you in fitting the roof rack tray or load bars to your specific vehicle.

Please refer to the next page for a list of all the components, quantities and tools required.

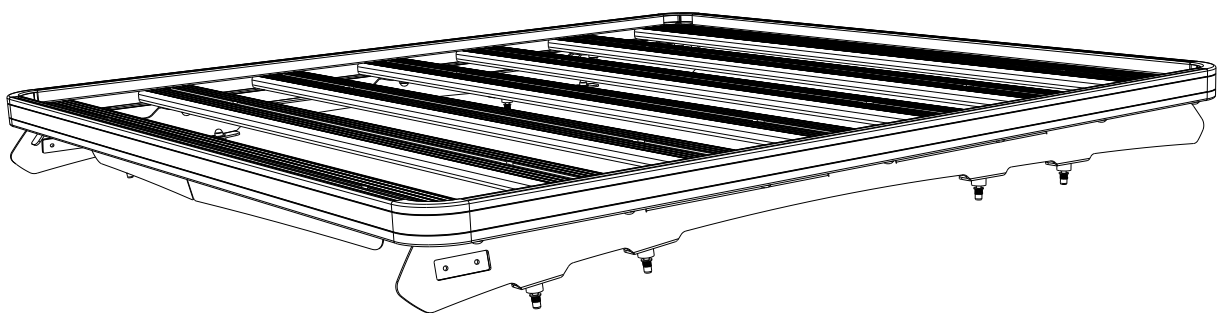

IMPORTANT WARNING!

IT IS CRITICAL THAT ALL FRONT RUNNER PRODUCTS BE PROPERLY AND SECURELY ASSEMBLED AND ATTACHED TO YOUR VEHICLE. IMPROPER ATTACHMENT COULD RESULT IN AN AUTOMOBILE ACCIDENT, AND COULD CAUSE SERIOUS BODILY INJURY OR DEATH. YOU ARE RESPONSIBLE FOR ASSEMBLING AND SECURING ALL FRONT RUNNER PRODUCTS TO YOUR VEHICLE, CHECKING THE ATTACHMENTS PRIOR TO USE, AND PERIODICALLY INSPECTING THE PRODUCTS FOR ADJUSTMENT, WEAR AND DAMAGE. THEREFORE, YOU MUST READ AND UNDERSTAND ALL OF THE INSTRUCTIONS AND PRECAUTIONS SUPPLIED WITH YOUR FRONT RUNNER PRODUCT PRIOR TO INSTALLATION OR USE. IF YOU DO NOT UNDERSTAND ALL OF THE INSTRUCTIONS AND CAUTIONS, OR IF YOU HAVE NO MECHANICAL EXPERIENCE AND ARE NOT THOROUGHLY FAMILIAR WITH THE INSTALLATION PROCEDURES, YOU SHOULD HAVE THE PRODUCT INSTALLED BY A PROFESSIONAL INSTALLER OR OTHER QUALIFIED PERSONNEL.

NOTE: Front Runner will not be responsible for any damage caused by the failure to install the product according to these instructions.

Please call us if you have any questions about the installation of this product.

1

GET ORGANIZED

IN THE BOX

1	2 X	Foot Rail 1LH & 1RH
2	8 X	M6 Nut Cap
3	8 X	M6 x 35 Hex Bolt
4	8 X	M6 SS Spring Washer
5	8 X	M6 x 19 x 1SS Flat Washer
6	8 X	Spacer 19 x 12.58 x 12
7	8 X	M6 Rivnut
8	14 X	M8 Nut Cap
9	14 X	M8 Nyloc Nut
10	14 X	M8 x 16 x 1.6SS Flat Washer
11	14 X	M8 x 20 Hex Bolt
12	1 X	Foot Rail Seal Kit

TOOLS NEEDED

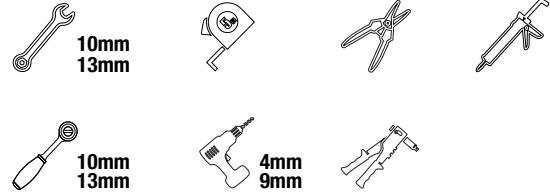
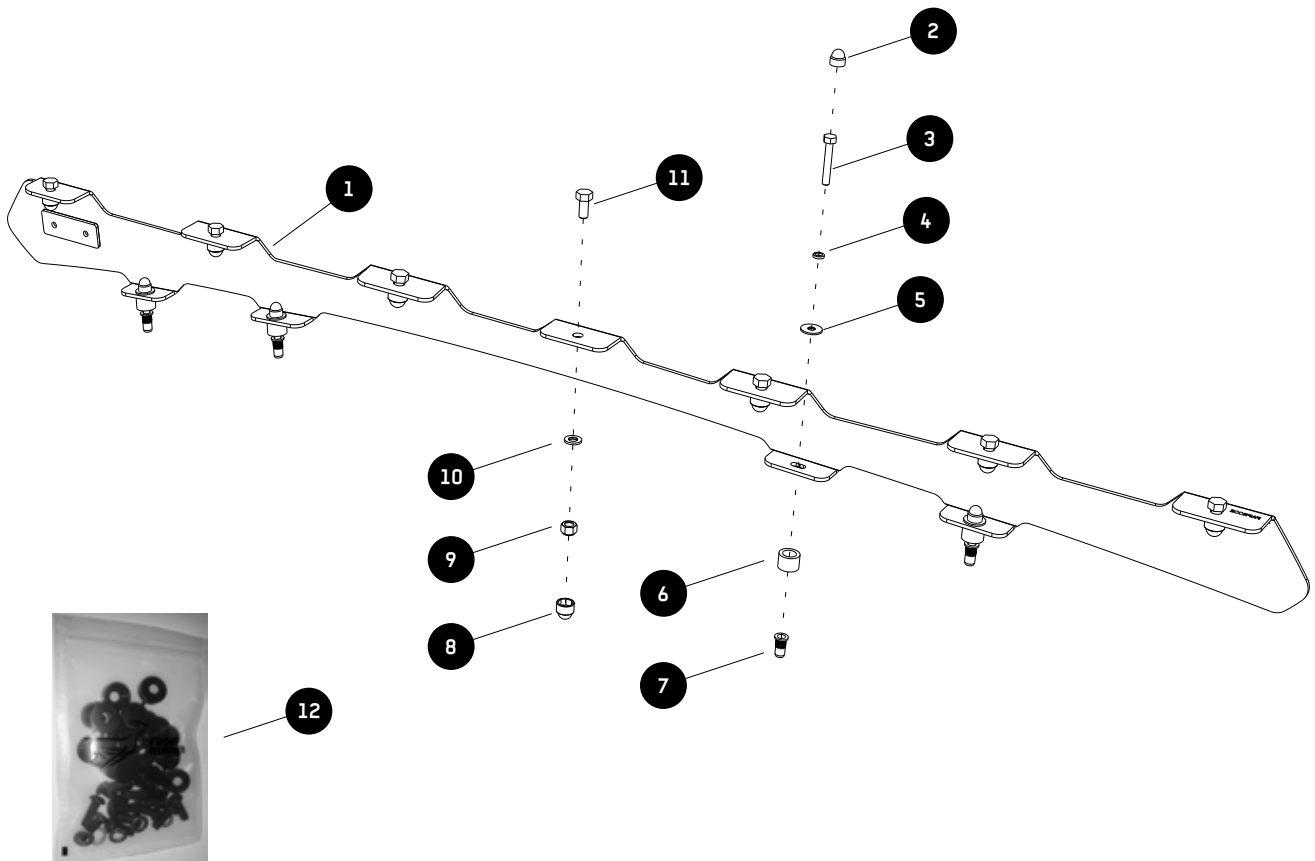

FIGURE 1.1



2

FIT AND SECURE

2.1

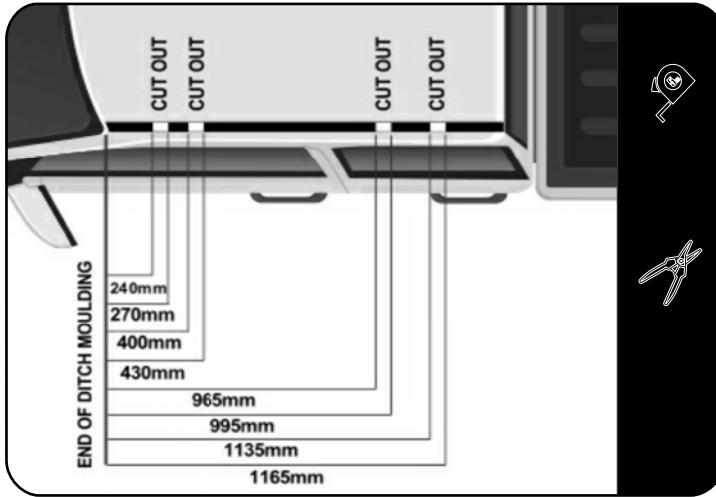

Starting at the front of the vehicle's roof, measure and mark the dimensions as shown onto each of the ditch mouldings. Remove the two ditch mouldings and cut on each of your markings. Make sure to mark the various pieces so that you are able to place them back onto the vehicle in their correct positions.

2.2

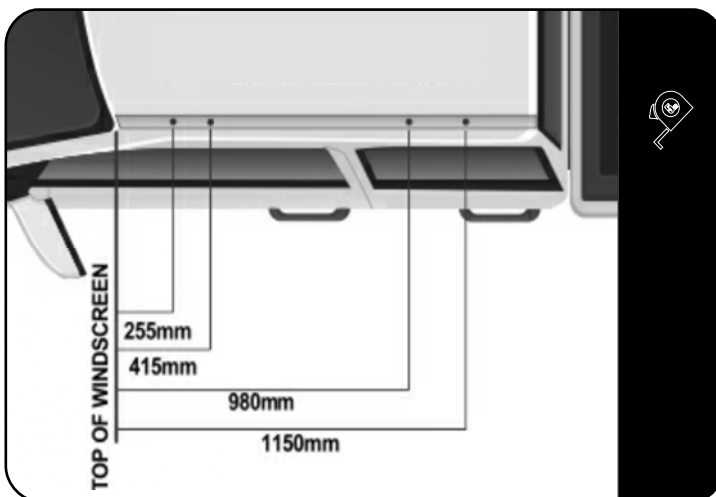

Make the following four markings as shown in the center of each ditch in the vehicle's roof.

2.3



Before drilling the holes in the roof, take both 4 & 9 mm drill bits and wrap a band of insulation tape around the drill bits to act as a stopper to prevent you from drilling to deep as there are airbags located below where you will be drilling. Drill the 8 holes you marked earlier, starting with a 4mm pilot hole before going to the 9mm hole. There is no need for a lot of downward pressure. Let the drill do the work.

2**FIT AND SECURE**

2.1

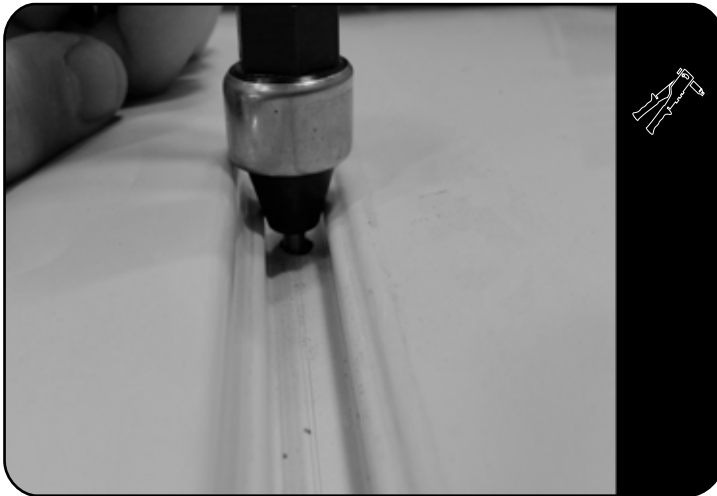

Using a Rivnut Tool, insert an M6 Rivnut (Item 10) into each of the eight 9mm holes drilled in Step 2.3.

2.2

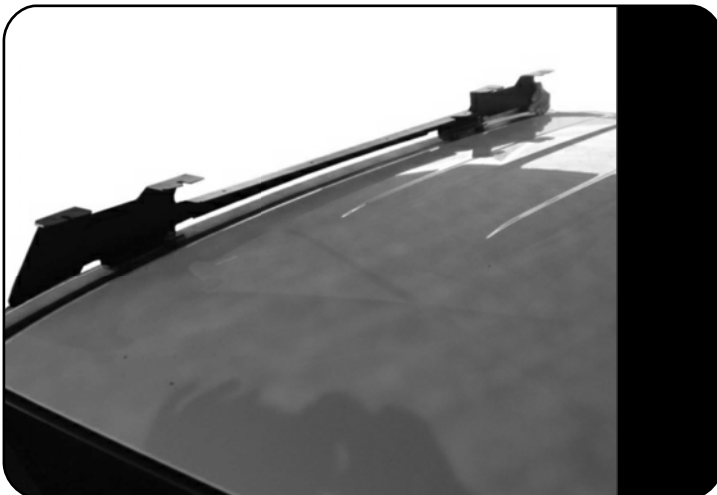

Place the various sections of ditch moulding back into position on the vehicle's roof. Place a Spacer (Item 6) over each of the holes drilled in Step 2.3.

Place the Foot Rails (Item 1) onto the Spacers, aligning the holes in the base of the Foot Rails with the center of the Spacer. The product sticker should be at the front of the vehicle and must face outward.

2.3

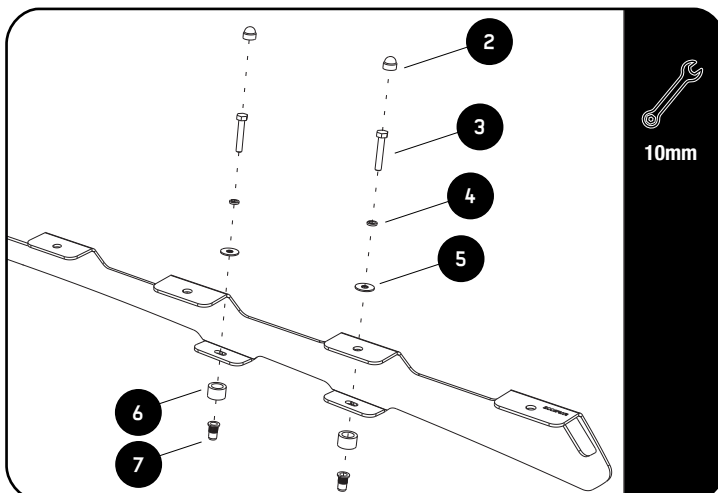

Place a bead of silicone onto the thread of each Hex Bolt before fastening.

Secure the Foot Rails to the vehicle using M6 x 35 Hex Bolts, M6 Spring Washers and M6 x 19 x 1SS Flat Washers (Items 3, 4 & 5).

Once fastened, place M6 Nut Caps (Item 2) over the head of each bolt.

3

FIT AND SECURE

3.1

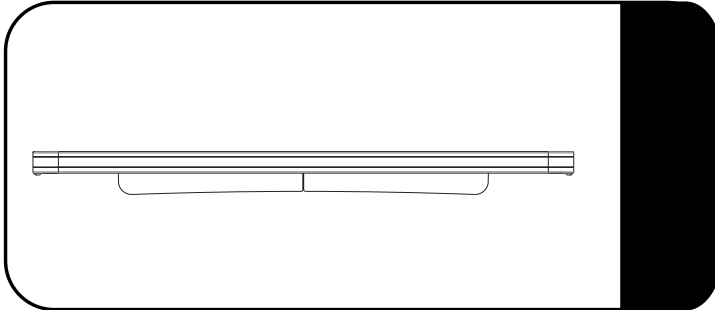

Make sure that the wind deflector is installed before you proceed to the next step.

3.2

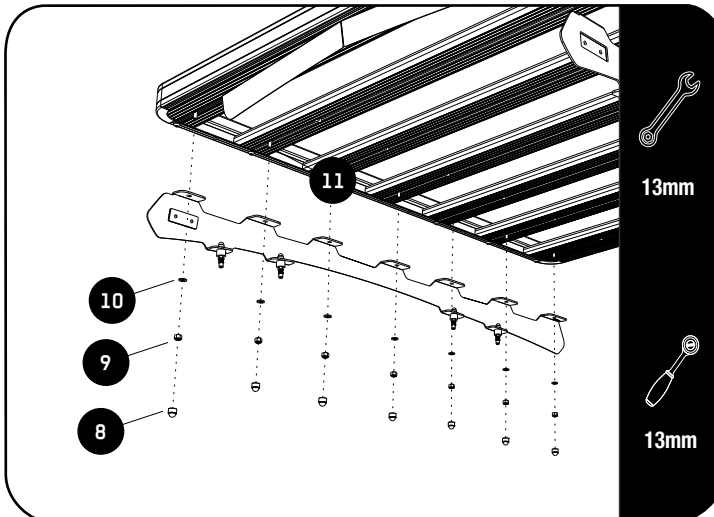

Fit your roof rack to the Foot Rails using M8 x 20 Hex Bolts, M8 x 16 x 1.6SS Flat Washers and M8 Nyloc Nuts (Items 9, 10 & 11).

3.3

Center the rack and tighten fully. Use M8 nut caps (Items 8) to finish off the nuts.



4

COMPLETION

4.1

Congratulations! You did it. Take a step back and admire your work!



5

INSTALL OTHER VEHICLE AND RACK ACCESSORIES

Now's the time to visit your favorite Front Runner Dealer in person or online.

IMPORTANT!

FRONT RUNNER RACK KITS OFTEN HAVE A HIGHER LOAD RATING THAN THE VEHICLES THEY ARE MOUNTED TO. PLEASE REFER TO YOUR SPECIFIC VEHICLE MANUFACTURER FOR A RECOMMENDED ROOF RATING. FRONT RUNNER CANNOT BE RESPONSIBLE FOR IMPROPER LOADING BEYOND THE VEHICLE MANUFACTURER'S STATED LOAD CAPACITY.

Be sure to tag us. We love to see our gear in action! #FrontRunnerOutfitters #BornToRoam

Share your adventures on: 