



# RHINO-RACK

## Toyota 100 Series Land Cruiser RTLB2 Backbone

**Fit Time:** 2 Hours

**Layout:**

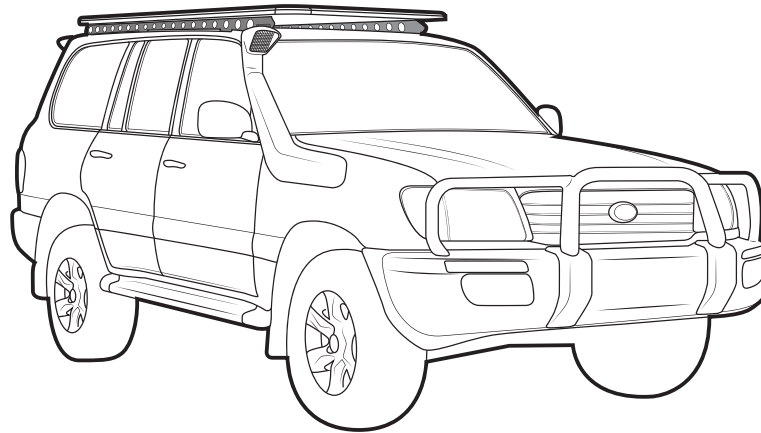

### IMPORTANT INFORMATION

**Maximum carrying capacity:**

Suitable Pioneers	On Road Cargo Allowance	Off Road Cargo Allowance	Static Allowance	Roof Allowance	Rack Weight
42103B	<b>81kg / 179lb</b>	<b>57kg / 126lb</b>	321kg / 708lb	<b>120kg / 265lb</b>	39kg / 86lb
45103B	<b>78.5kg / 173lb</b>	<b>54.5kg / 120lb</b>	318.5kg / 702lb		41.5kg / 91lb
41103	<b>76.5kg / 169lb</b>	<b>52.5kg / 116lb</b>	316.5kg / 698lb		43.5kg / 96lb
42104B	<b>78.5kg / 173lb</b>	<b>54.5kg / 120lb</b>	318.5kg / 702lb		41.5kg / 91lb
45104B	<b>75.5kg / 167lb</b>	<b>51.5kg / 114lb</b>	315.5kg / 696lb		44.5kg / 98lb
41104	<b>72.5kg / 160lb</b>	<b>48.5kg / 107lb</b>	312.5kg / 689lb		47.5kg / 105lb

**Roof Allowance:** Total permissible weight attached to the roof of the car. This is inclusive of the weight of the roof rack system

**Cargo Allowance:** Total permissible weight allowed on top, and attached to roof racks whilst the vehicle is in motion

**Static Allowance:** Total permissible weight allowed on top, and attached to roof racks whilst the vehicle is stationary

Please refer to your vehicle manufacturers handbook for maximum carrying capacity. Always use the lower of the two figures. Load must be evenly distributed over the entire Pioneer. Weight of roof rack accessories is to be included in cargo allowance.

**Warning:**

- Check Part No. and/ or Kit is correct for use with your vehicle
- Do not attempt to fit the rack system to your vehicle unless you fully understand these fitting instructions. Please direct any questions regarding fitting to the dealer from where the roof racks were purchased.
- **Use only non-stretch fastening ropes or straps.**
- The handling characteristics of the vehicle changes when you transport a load on the roof. For safety reasons we recommend you exercise extreme care when transporting wind-resistant loads. Special consideration must be taken into account when cornering and braking.
- Although the system is tested and approved to AS1235-2000 / ISO 11154, off-road conditions can be much more rigorous. Extreme care must be taken in off road conditions
- 

**Recommendations:**

It is essential that all bolt connections be checked after driving a short distance when you first install your roof racks. Bolt connections should be checked again at regular intervals (once a week is enough, depending on road conditions, usage, loads and distances travelled). You should also check the roof racks each time they are re-fitted. Always make sure to fasten your load securely. Please also ensure that all loads are evenly distributed and that the centre of gravity is kept as low as possible and must be entirely contained within the extents of the roof racks.

**Note for Dealers and Fitters:**

It is your responsibility to ensure these fitting instructions are given to the end user or client

Rhino-Rack, 3 Pike St, Rydalmere  
NSW 2116, Australia  
(02) 8846 1900  
rhinorack.com.au

Document No: R1450  
Prepared By: KE  
Authorised By: NC

Issue No: 05  
Issue Date: 01/04/2019

These instructions remain the property of Rhino-Rack Australia Pty. Ltd. and may not be used or changed for any other purpose than intended.



# Toyota 100 Series Land Cruiser RTL B2 Backbone

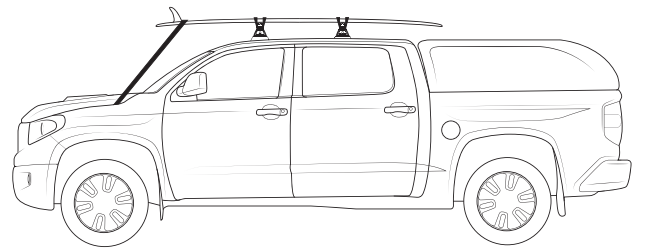
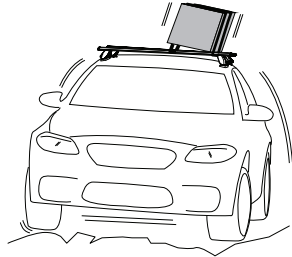
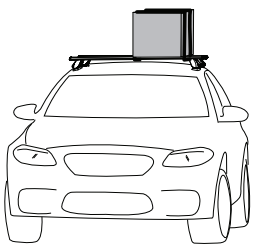
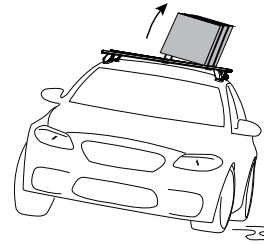
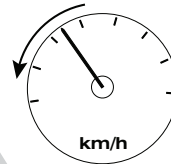
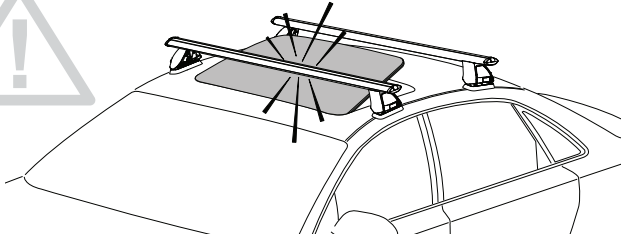
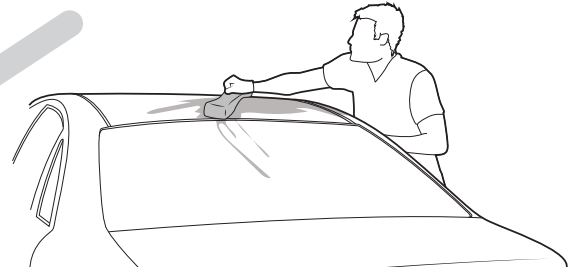
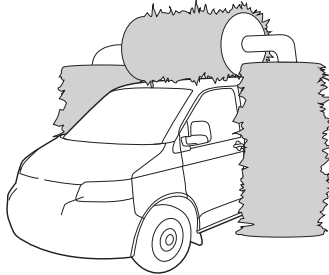
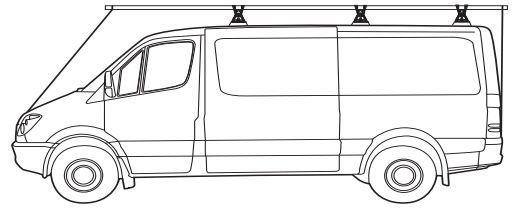
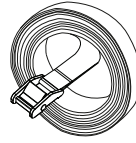
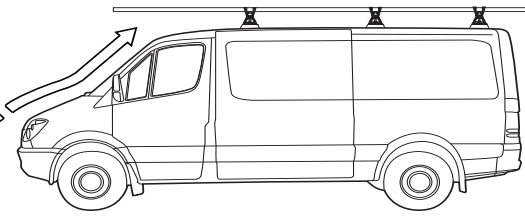

**System Weight: 34.5kg - 42.5kg**

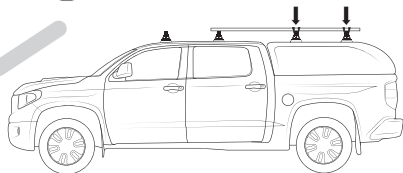
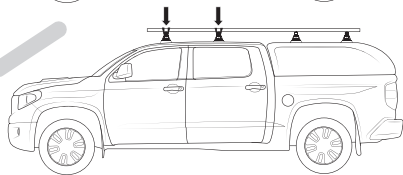
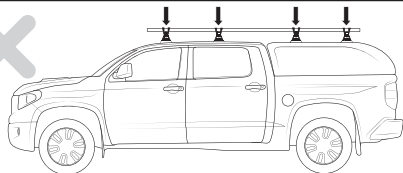
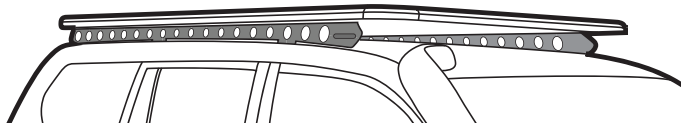

**Ensure Ladder is well supported on the ground to help support tent. Take extreme caution when climbing heights above 1.2m/4ft.**

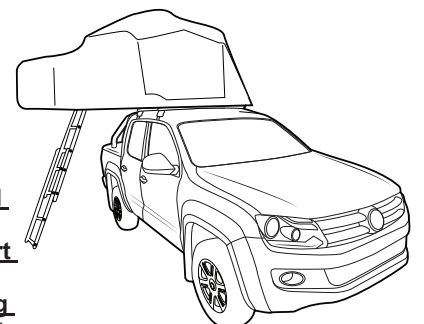



# Toyota 100 Series Land Cruiser RTLB2 Backbone

## Parts List

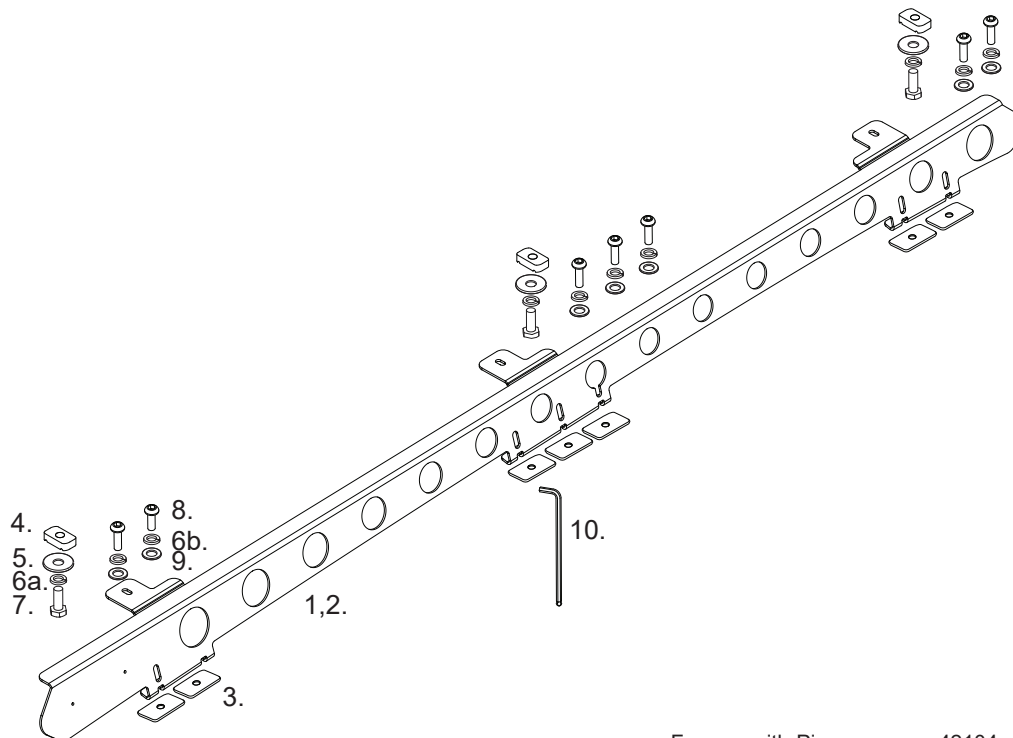

Left Side Pictured

For use with Pioneer range 42104, 45104, 41104, 42107, 45107 or 41107. Pioneer range sold as separate.

Item	RTLB2 Kit	Qty	Part No.
1	Land Cruiser 100 Series Left Rail	1	CA1768
2	Land Cruiser 100 Series Right Rail	1	CA1769
3	Butyl Patch 40x25 M8 Hole	14	CA1260
4	M8 Channel Nut	6	N003
5	M8x24x2 Flat Washer	6	W064-BLK
6a	M8 Spring Washer	14	W031
6b	M8 Spring Washer black	6	W019
7	M8x20 Hex Setscrew	6	B020-BLK
8	M8x25 Button Head Screw	14	B140
9	M8x17 Flat Washer	14	W020
10	5mm Ball-end Key	1	-
11	Instructions	1	R1450

### Tools Required:

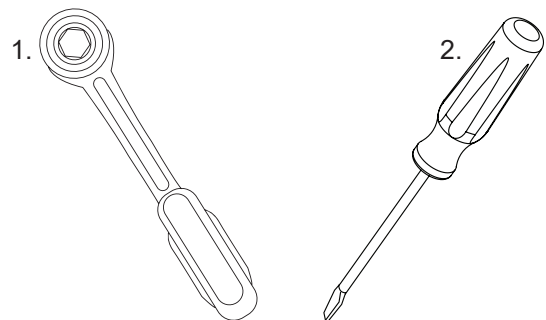

1. Socket Wrench
2. Flat blade Screw Driver
3. Rattle gun

## Removing Fixed point mount covers

Move to the roof of the vehicle. If your car is not fitted with factory roof rails, remove the eight mounting point covers (four per side). Remove Sliding the cover forward and rotating out. Remove the two M8 bolts, washers and bracket. Note that these are not required to fit the Backbone, store these in a safe place.

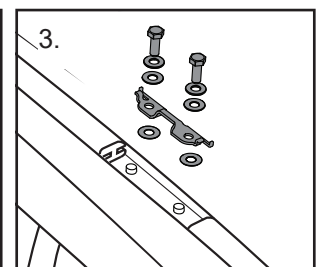
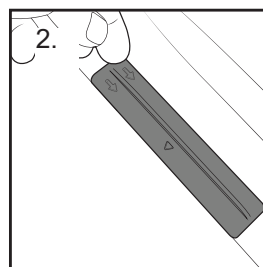
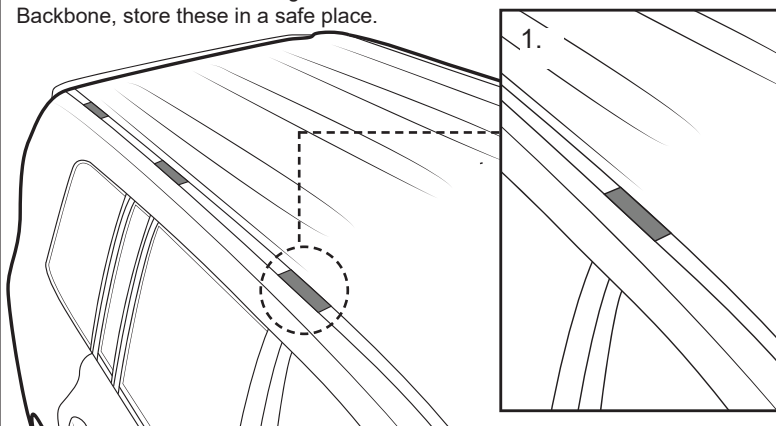

When loosening bolts, loosen bolts progressively together. Failure to do so can dislodge nutplate within roof cavity



# Toyota 100 Series Land Cruiser RTL B2 Backbone

## Removing Factory Elevated Roof Rails

**1** If the Toyota 100 Series Land Cruiser has factory elevated Roof Rails you will need to remove these before installing the Backbone. To access the hardware fixing the Roof Rails to the roof, you must first remove the Plastic Covers. You will need a flat head screwdriver to pry the Plastic Covers off. To minimise potential damage to the vehicle, it's recommended to pad the metal shaft of the screwdriver with multiple layers of masking tape. This will pad the screwdriver if it hits the bodywork of the vehicle.

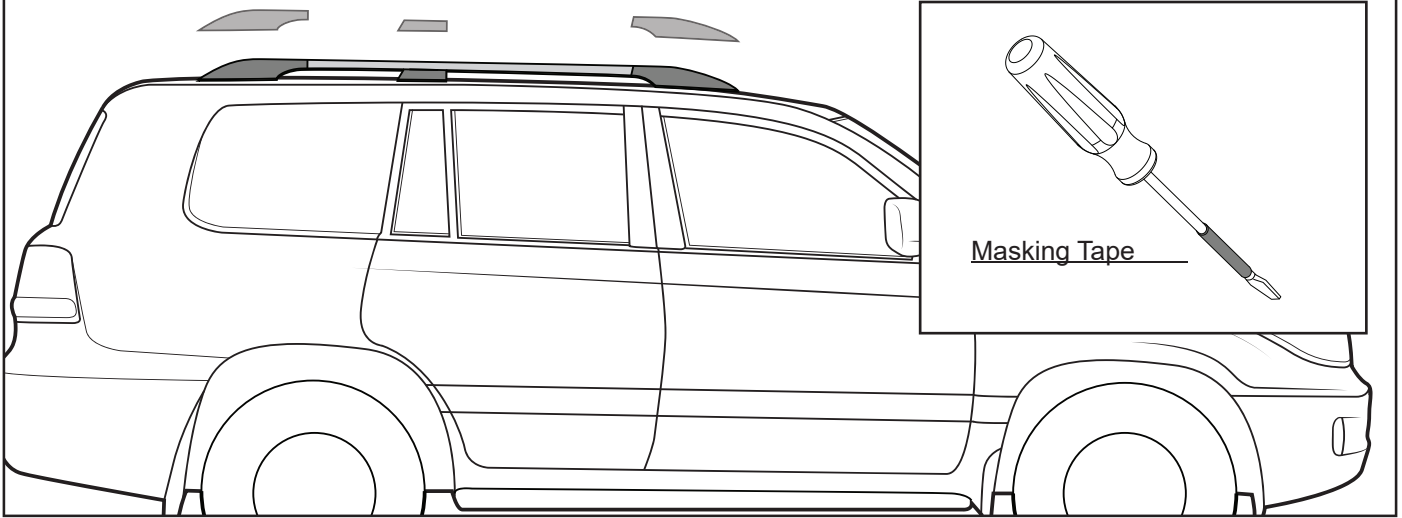

**2** Using the tape covered screwdriver, unclip the two outside clips holding the covers onto the roof rails. You will need to flex the outside of the covers and find where the clips are resisting. Lever downwards until the clips pop out.

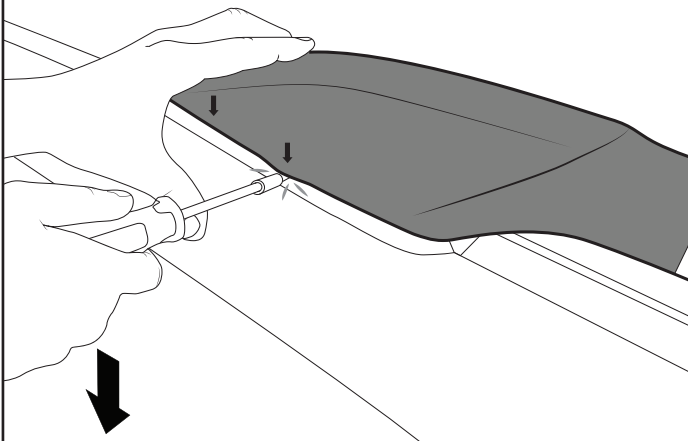

**3** After the outside clips have popped out, push the front of the cover in towards the car. This will release the inside clips of the cover.

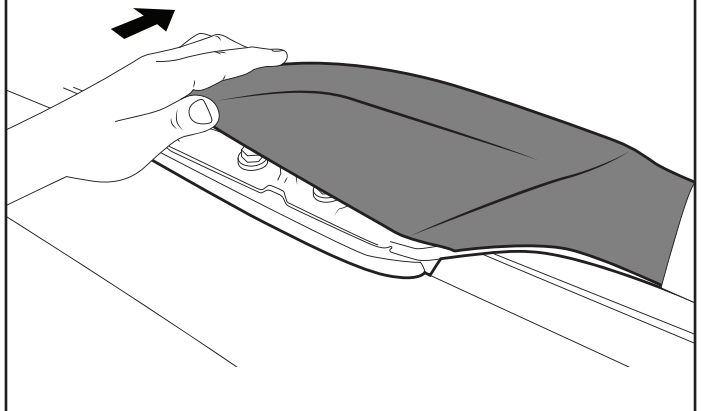

**4** Once all clips have been released, pull cover forwards and up to remove completely.

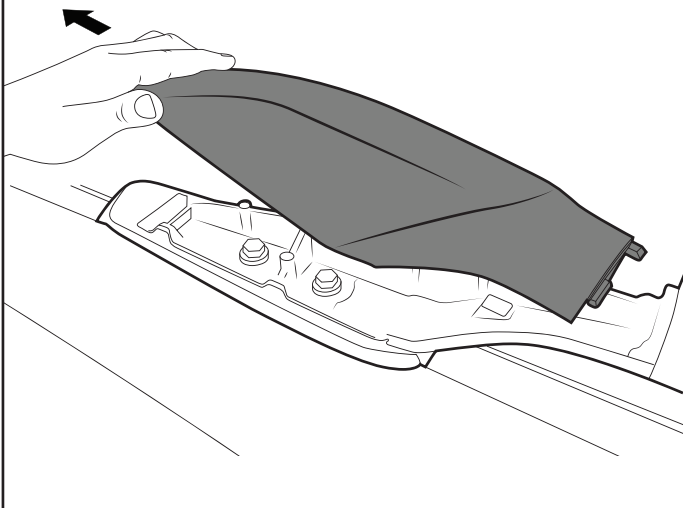

**5** Remove all hardware holding down roof rails. Note that these are not required to fit the Backbone, store these in a safe place. Complete steps 2-5 for front and rear covers, both left and right side.

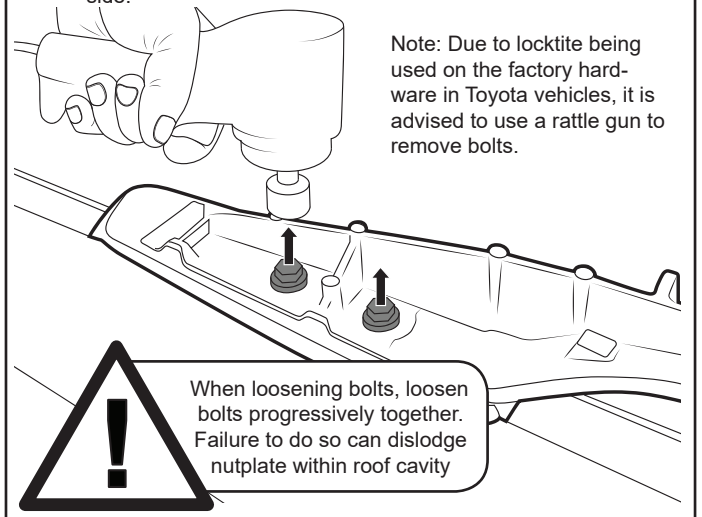



## Toyota 100 Series Land Cruiser RTL B2 Backbone

- 6** Move to the centre fixture of the roof rail, lean over the rail and position the flat head screwdriver as indicated in image below. Lever the case so the inside clip releases (see Step 8)

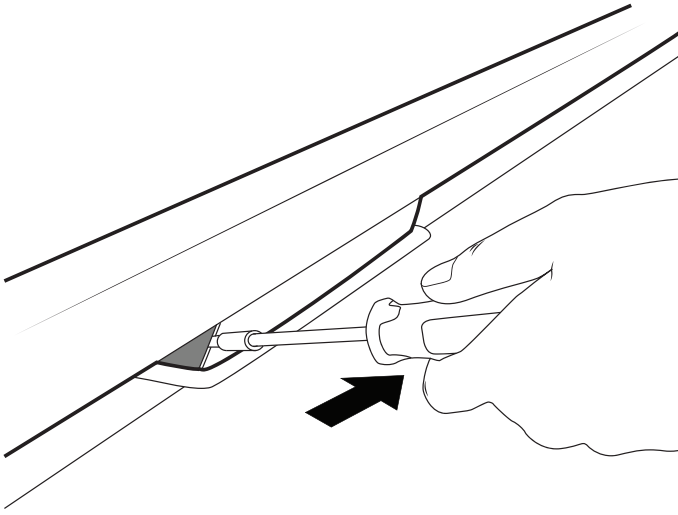

Note: View looking from centre of vehicle outwards

- 7** After one clip has released, pull outwards and remove entire car, revealing hardware fixing centre of elevated roof bars.

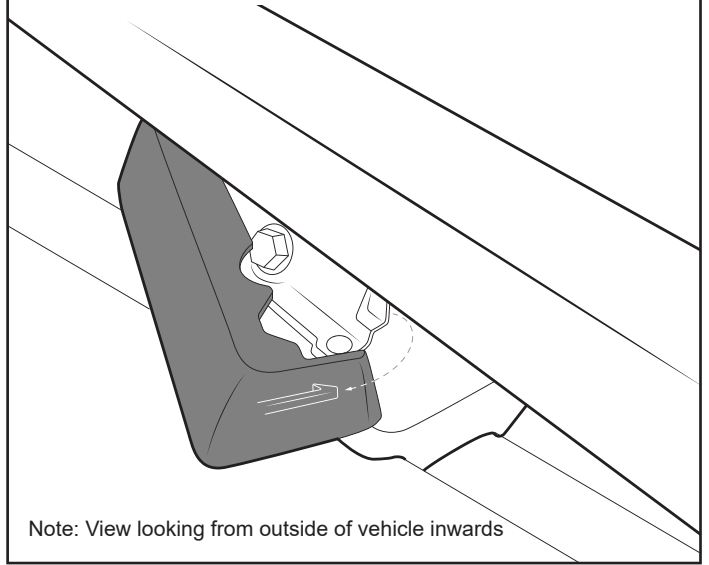

Note: View looking from outside of vehicle inwards

- 8** Remove exposed bolt completely. After removing the bolt, the roof rail is ready to be lifted carefully off of the roof. There will still be hardware to remove from the centre fixing point (see Step 10)

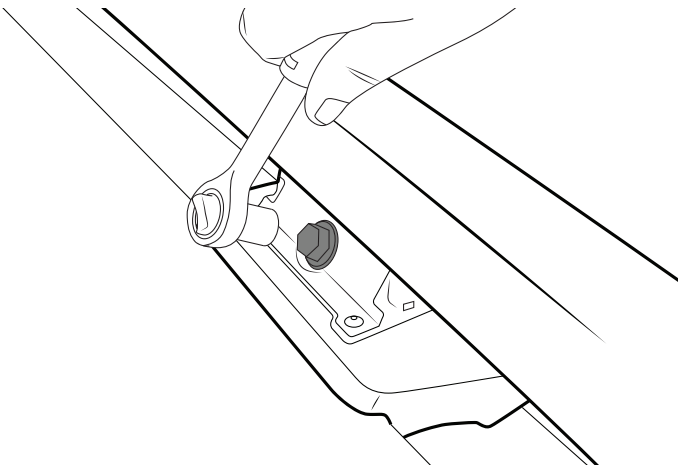

- 9** Carefully lift directly upwards and remove the elevated roof rail from the roof.

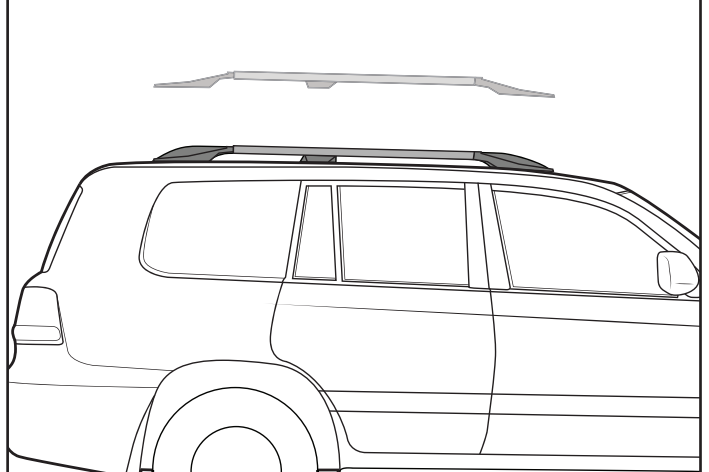

- 10** Once the rail has been removed, loosen and remove remaining hardware from middle fixing points.

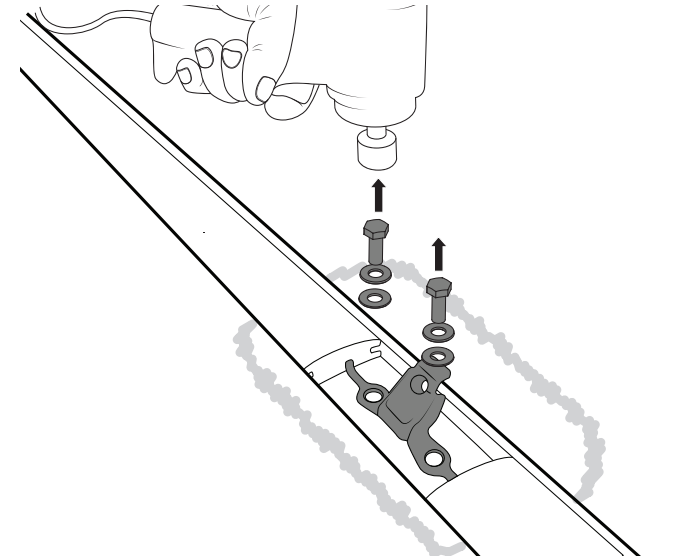

- 11** Whilst the roof is bare, take the time to remove any dirt that may have built up underneath the rubber seals and polish the paint work

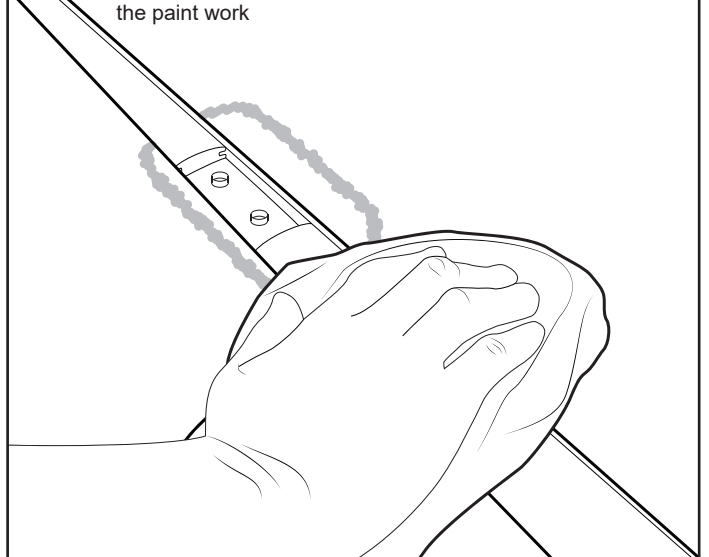



# Toyota 100 Series Land Cruiser RTLB2 Backbone

## Mounting Backbone Rails and Pioneer Platform

- 1** Remove backing tape of the butyl patch and position over the top of mounting holes. Ensure patch has adhered to channel surface securely. Repeat this step for all 14 holes.

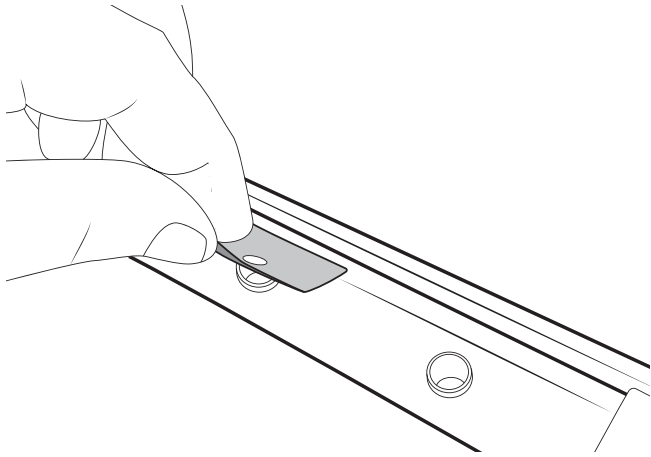

- 2** Once all butyl patches are placed, remove top cover tape, revealing just the Butyl. This will create a watertight seal and protect the paint from metal contact.

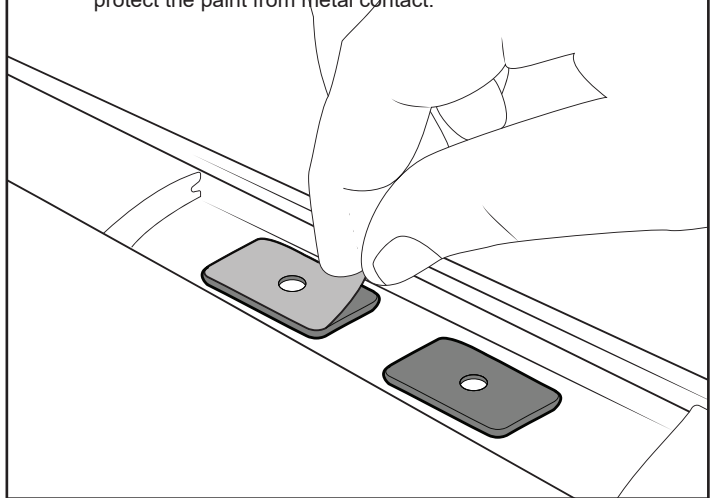

- 3** Place one side of the Backbone onto the roof of the vehicle. Line up the mounting points of the bracket to the those exposed on the roof in the previous steps.



Front View:

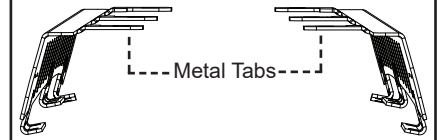

Metal Tabs face in toward the vehicle.

- 4** Using the M8 Button Screws, M8 Spring and Flat Washers, place the hardware into mounting holes of rails. Make sure hardware and holes align with fixed roof mounts before proceeding to Step 5.

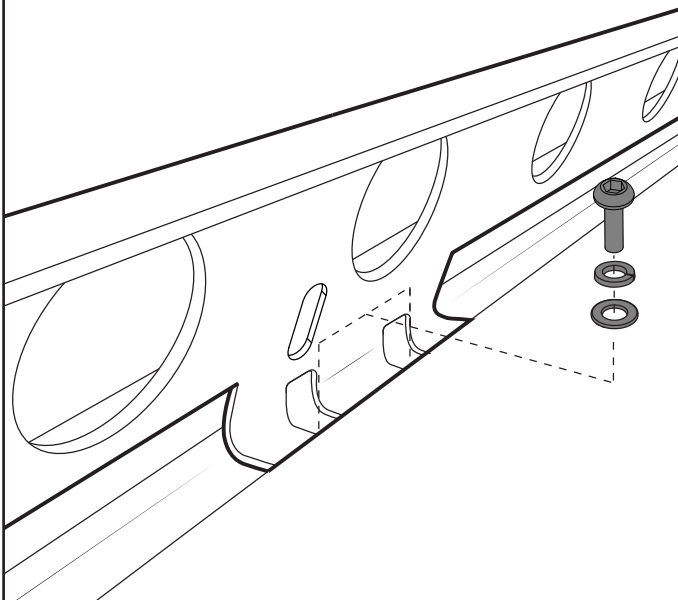

- 5** Start carefully securing Backbone by tightening M8 Button Screw hardware into the roof fixed mount points with a 5mm Ball End Allen Key.

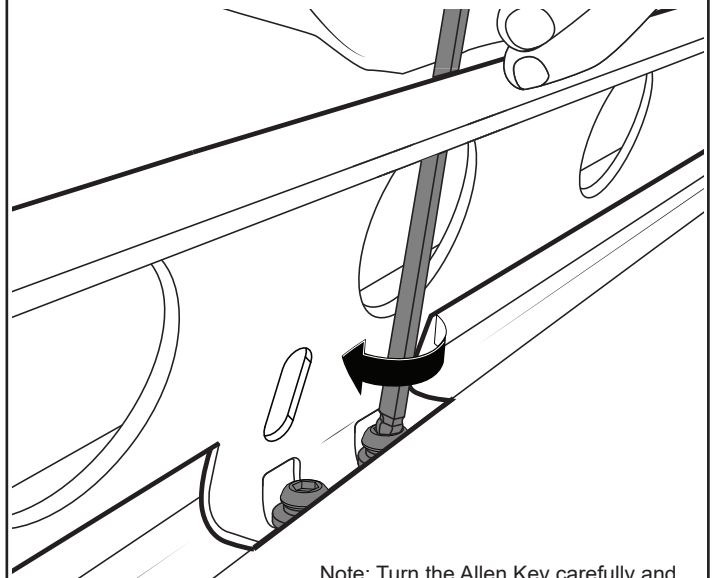

Note: Turn the Allen Key carefully and be sure not to damage the Button Head Screw. You will not be able to completely tighten the Screws.



# Toyota 100 Series Land Cruiser RTLB2 Backbone

**6** After all bolts have been tightened as much as possible with the ball end allen key, finish tightening using the short end of the allen key as shown.

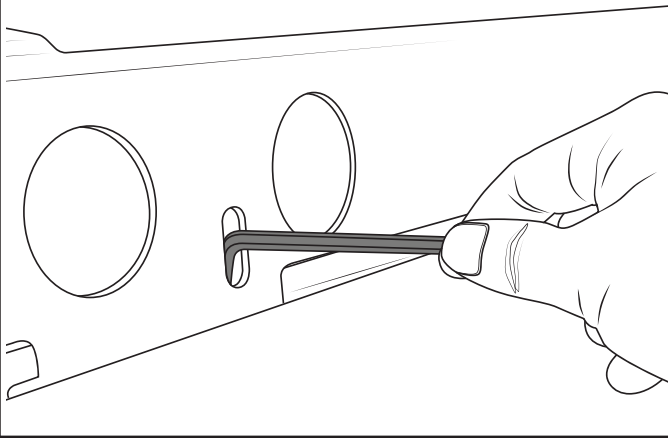

**7** Repeat steps 3-6 for securing opposite side Backbone rail.

Ensure both plates are securely positioned on the car. Check each bolt before proceeding to attaching the Pioneer tray to the backbone rails.

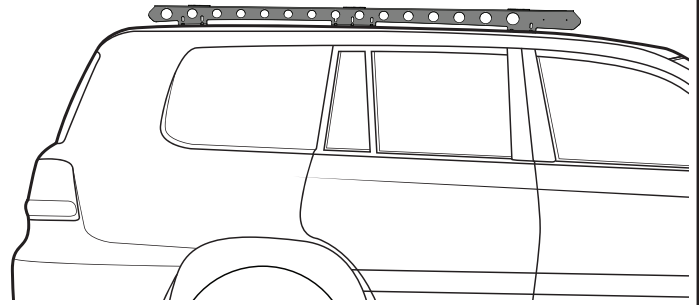

**8** Assemble M8 hardware as pictured below. Complete this for the six tabs on top of the backbone rails (3 each rail).

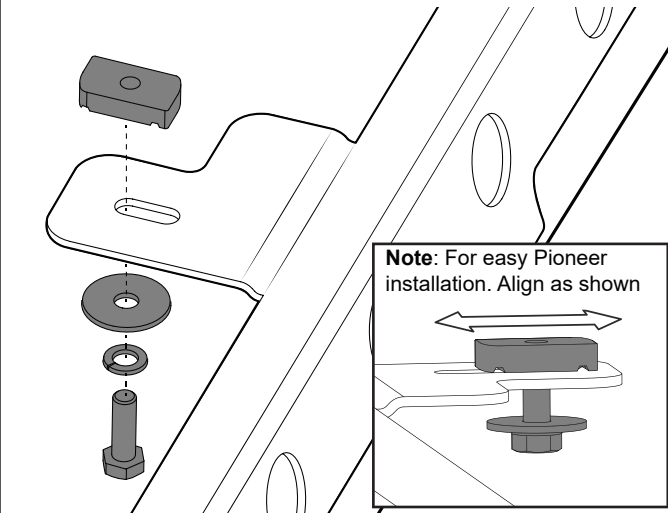

**9** Install Pioneer underbars into positions indicated. Drilled locations requires an 8.5mm drill bit

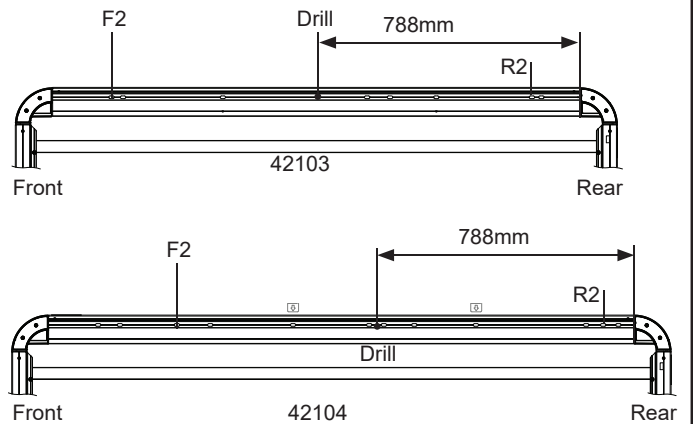

**10** After underbars have been correctly fitted, place the Pioneer tray on top of the Backbone rails. Align the underbars with the top tabs and ensure the M8 hardware fits into underbar channel.

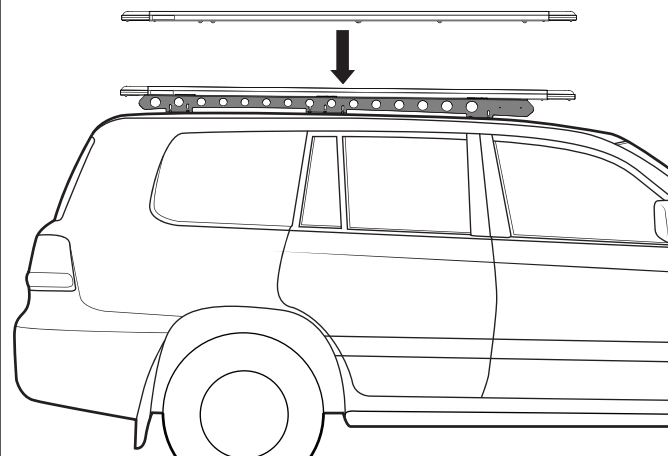

**11** Once Pioneer underbars have been aligned properly, tighten all M8 hardware using 13mm socket wrench or 13mm spanner. Ensure channel nut has rotated within Pioneer underbar and is fixing Pioneer securely.

