

RHINO-RACK

Ford Ranger with Factory Mount Backbone - RFRB2

Fit Time: 1 Hour

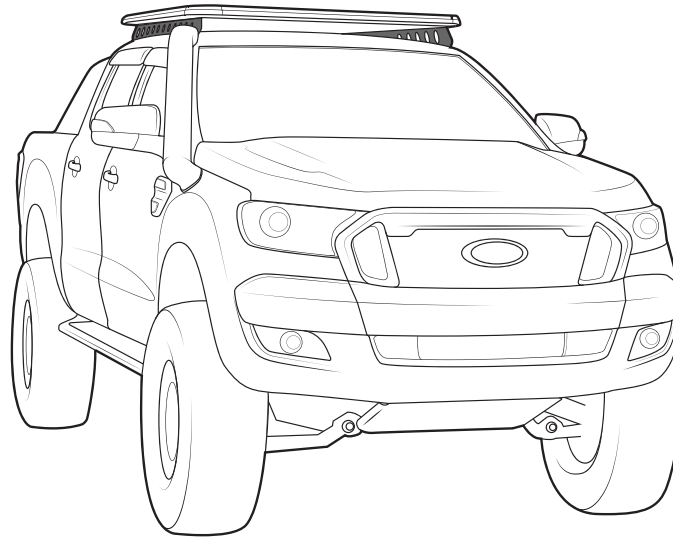

IMPORTANT INFORMATION

Maximum carrying capacity:

Suitable Pioneers	On Road Cargo Allowance	Off Road Cargo Allowance	Static Allowance	Roof Allowance	Rack Weight
42100B	71kg / 157lb	51kg / 112lb	331kg / 730lb	100kg / 220lb	29kg / 64lb
45100B	69kg / 152lb	49kg / 108lb	329kg / 725lb		31kg / 68lb
41100	66.5kg / 147lb	46.5kg / 103lb	326.5kg / 720lb		33.5kg / 74lb

Roof Allowance: Total permissible weight attached to the roof of the car. This is inclusive of the weight of the roof rack system

Cargo Allowance: Total permissible weight allowed on top, and attached to roof racks whilst the vehicle is in motion

Static Allowance: Total permissible weight allowed on top, and attached to roof racks whilst the vehicle is stationary

Please refer to your vehicle manufacturers handbook for maximum carrying capacity. Always use the lower of the two figures. Load must be evenly distributed over the entire Pioneer. Weight of roof rack accessories is to be included in cargo allowance.

Torque settings

Unless stated otherwise in these instructions, all fasteners should be set to the following torque settings - M6: 4-5Nm (3-4lbs/ft), M8: 8-10Nm (6-7.5lbs/ft) and M10: 16-18Nm (12-13lbs/ft).

Warning:

- Check Part No. and/ or Kit is correct for use with your vehicle
- Do not attempt to fit the rack system to your vehicle unless you fully understand these fitting instructions. Please direct any questions regarding fitting to the dealer from where the roof racks were purchased.
- **Use only non-stretch fastening ropes or straps.**
- The handling characteristics of the vehicle changes when you transport a load on the roof. For safety reasons we recommend you exercise extreme care when transporting wind-resistant loads. Special consideration must be taken into account when cornering and braking.
- Although the system is tested and approved to AS1235-2000 / ISO 11154, off-road conditions can be much more rigorous. Extreme care must be taken in off road conditions

Recommendations:

It is essential that all bolt connections be checked after driving a short distance when you first install your roof racks. Bolt connections should be checked again at regular intervals (once a week is enough, depending on road conditions, usage, loads and distances travelled). You should also check the roof racks each time they are re-fitted. Always make sure to fasten your load securely. Please also ensure that all loads are evenly distributed and that the centre of gravity is kept as low as possible and must be entirely contained within the extents of the roof racks.

Note for Dealers and Fitters:

It is your responsibility to ensure these fitting instructions are given to the end user or client

Rhino-Rack, 3 Pike St, Rydalmere
NSW 2116, Australia
(02) 8846 1900
rhinorack.com.au

Document No: R1698
Prepared By: Kayle Everett
Authorised By: Chris Murty

Issue No: 03
Issue Date: 12/07/2018

These instructions remain the property of Rhino-Rack Australia Pty. Ltd. and may not be used or changed for any other purpose than intended.

Ford Ranger with Factory Mount Backbone - RFRB2

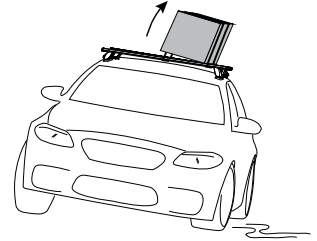
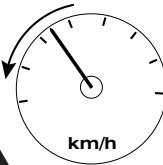
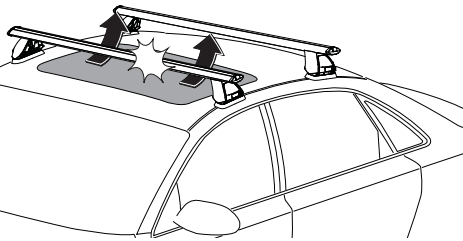
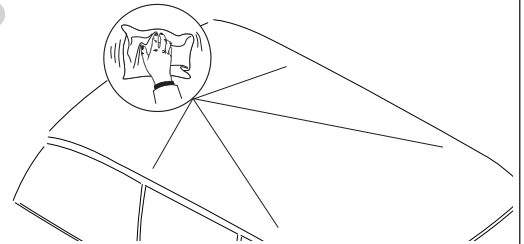
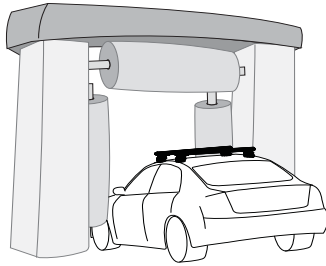
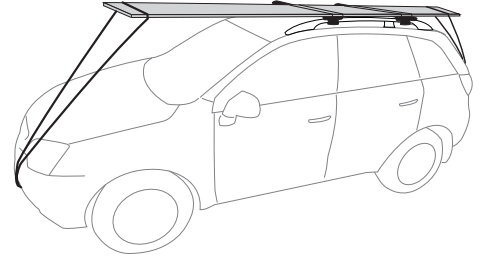
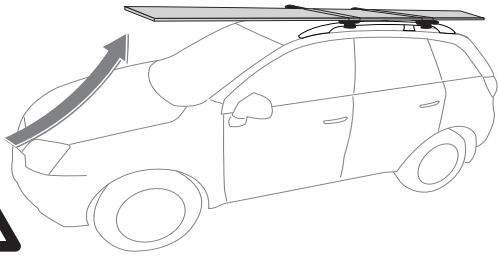

The handling characteristics of the vehicle changes when you transport a load on the roof. For safety reasons we recommend you exercise extreme care when transporting wind-resistant loads. Special consideration must be taken into account when cornering and braking.

Although the system is tested and approved to AS1235-2000 / ISO 11154, off-road conditions can be much more rigorous. Extreme care must be taken in off road conditions

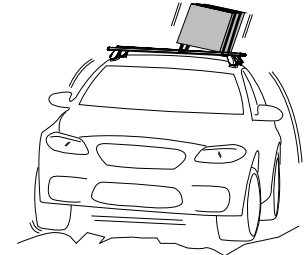
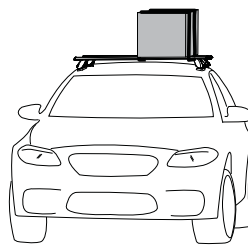

System Weight: 29 - 33.5kg

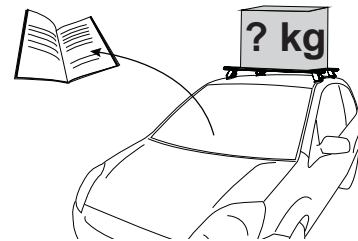
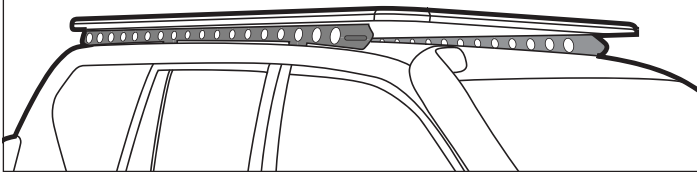

Static Load Rating: refer to front page



Ensure Ladder is well supported on the ground to help support tent. Take extreme caution when climbing heights above 1.2m/4ft.

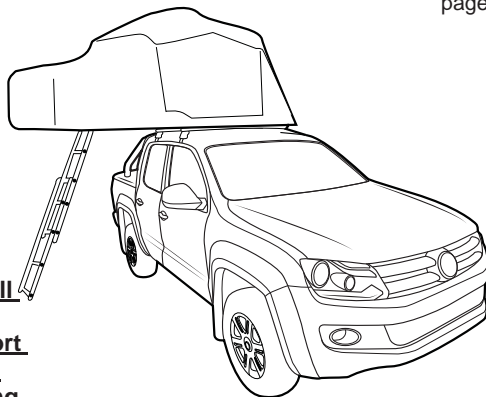

Paddle/ Surfboards should be fixed to the front of the vehicle.

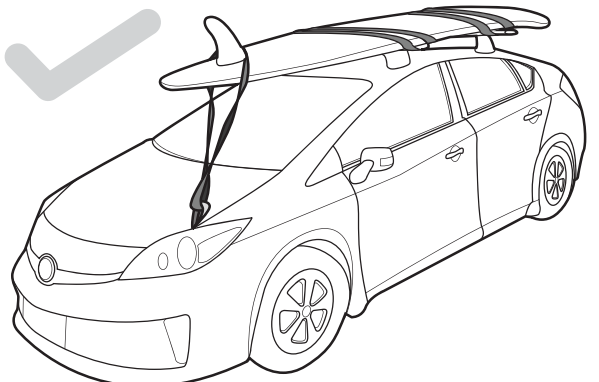

Ford Ranger with Factory Mount Backbone - RFRB2

Parts List

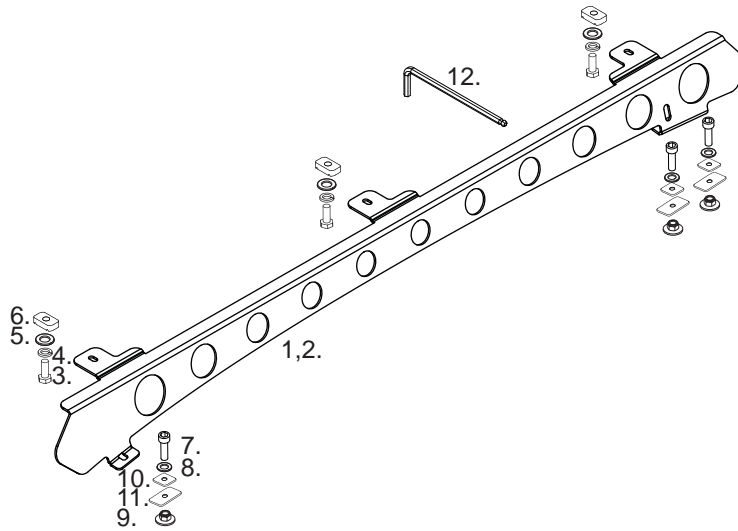

Item	RFRB2	Qty	Part No.
1	Wildtrack Backbone LHS	1	CA1793
2	Wildtrack Backbone RHS	1	CA1794
3	M8 x 20mm Hex Bolt	6	B020-BLK
4	M8 Spring Washer	6	W019
5	M8 x 24mm Flat Washer	6	W043
6	M8 Channel Nut	6	N003
7	M6 x 25mm Socket Head Screw	8	B054
8	M6 x 18mm Flat Washer	8	W031

9	M6 Nyloc Nut w/ Washer	8	N018
10	Butyl Patch 20x20	14	VA1266
11	Butyl Patch 40x25	6	CA1260
12	Allen Key	1	-
13	Instructions	1	R1698

Tools Required:

- 13mm Ring Spanner
- T30 Torx head key

Instructions

- 1 A: This Backbone fit requires factory rails to be removed from the vehicle. To achieve this the hood lining must be carefully dropped. This will allow access to the factory nuts installed under the roof rail. Unscrew these to remove the roof rail. There are 4 nuts to remove for each rail.

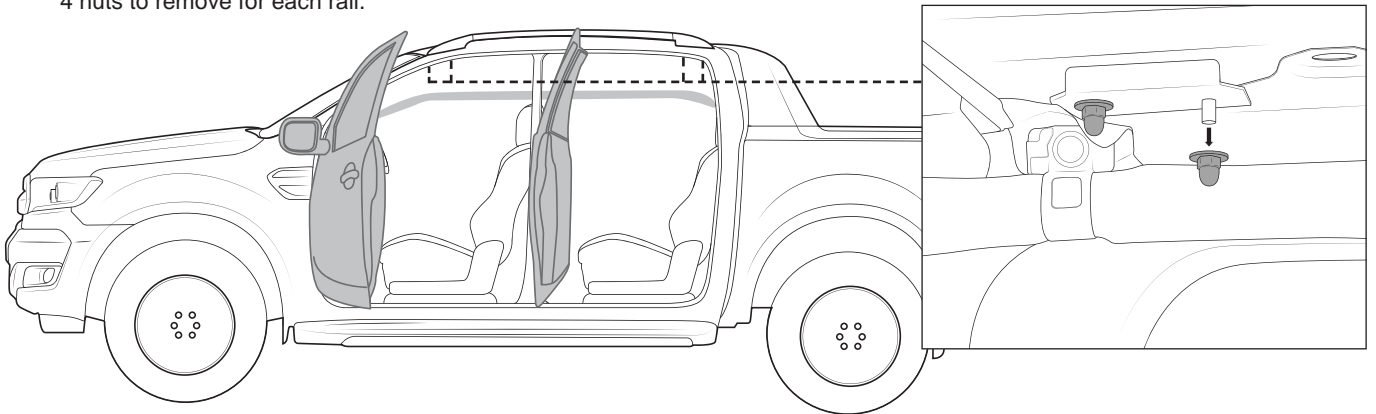

- B: With the rail hardware removed, lift off the factory rails from the vehicle.

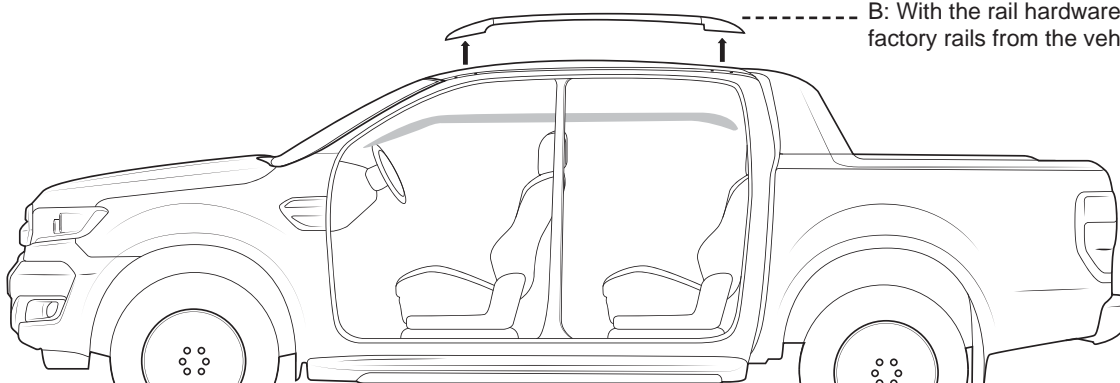

Ford Ranger with Factory Mount Backbone - RFRB2

- 2** For hole 1 in the roof only: Peel off one side of the backing tape on a 20x20 butyl patches provided. Place over the top of the exposed factory holes. Remove the top layer of backing.

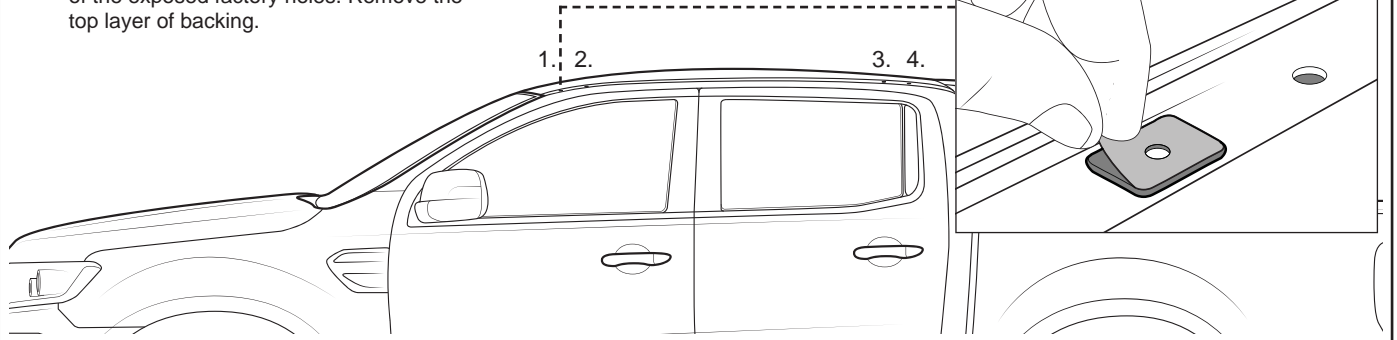

- 3** 1. Peel off one side of backing tape on the large butyl patches provided. Place over the top of holes 2-4 (shown above). Remove the top layer of backing.
2. Remove the backing tape off the smaller butyl patches and place these over the top of the larger butyl patches. Again, Remove the top layer of tape from the butyl patch.

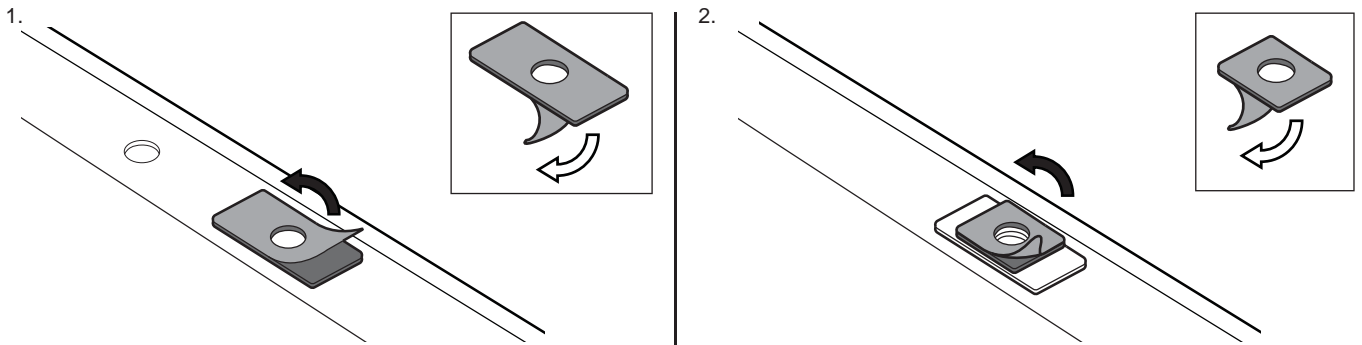

Note The backbone system can be fit in conjunction with a factory snorkel. Place butyl patches under the snorkel bracket as shown and fit as usual in steps 2 and 3.

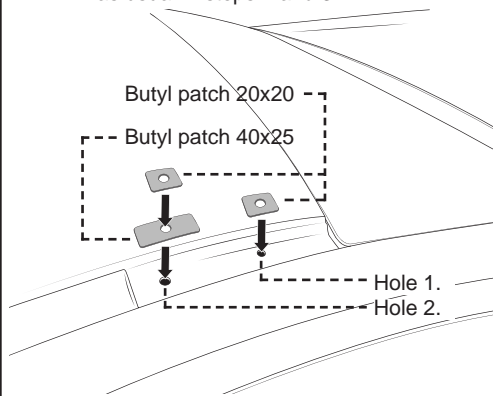

The snorkel bracket sits on the installed patches as shown. Fix in place with M6 x 25mm socket screws and M6 flat washers.

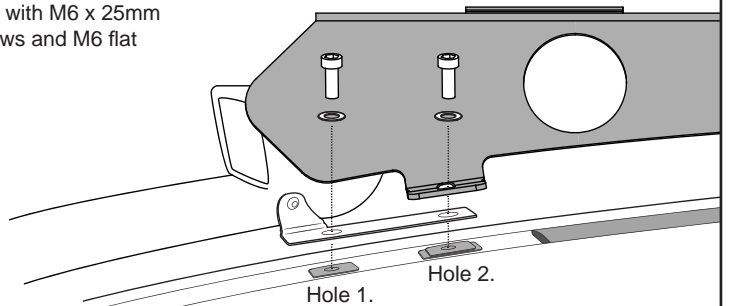

- 4** Place the backbone onto the vehicle.

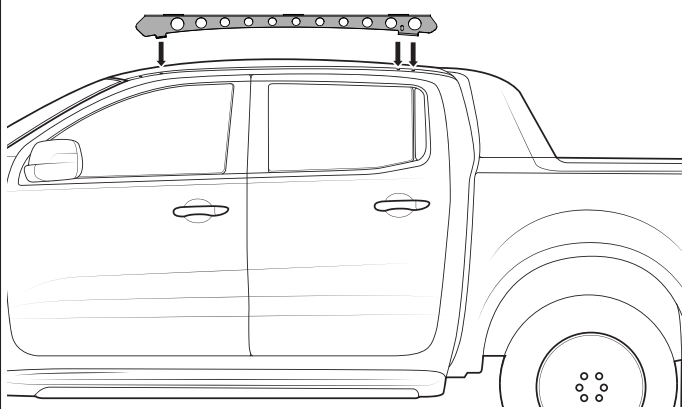

- 5** Fasten the backbone into place using the provided M6 Hardware; M6 x 25 socket head screw, M6 flat washer, and M6 combination nyloc.

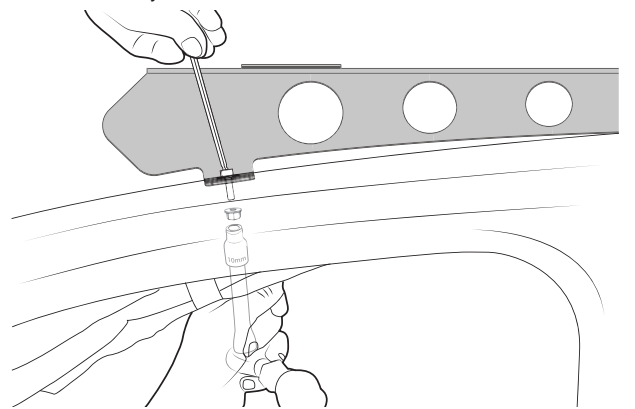

Ford Ranger with Factory Mount Backbone - RFRB2

6 Using the same hardware, fill the remaining hole in front of the backbone.

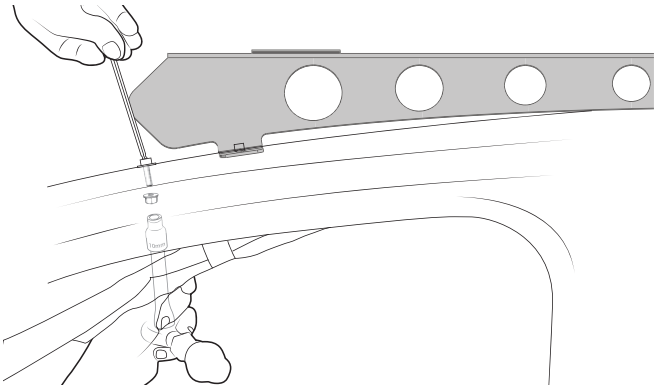

7 Replace the hood-lining within the vehicle.

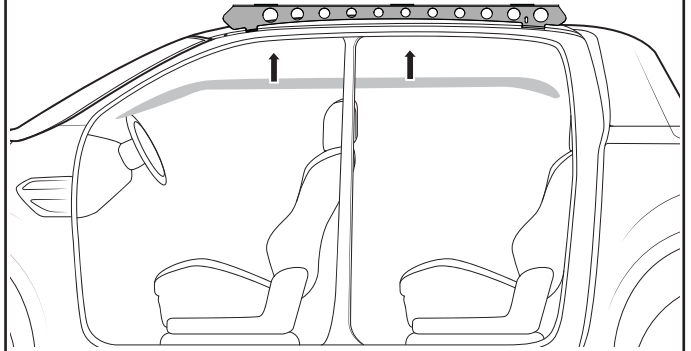

8 Assemble M8 hardware as pictured below. Complete this for the six tabs on top of the backbone rails.

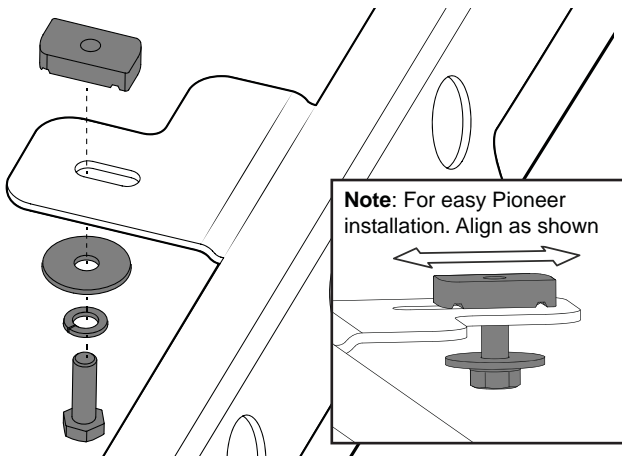

9 Install Pioneer Underbars with slots indicated (42100).

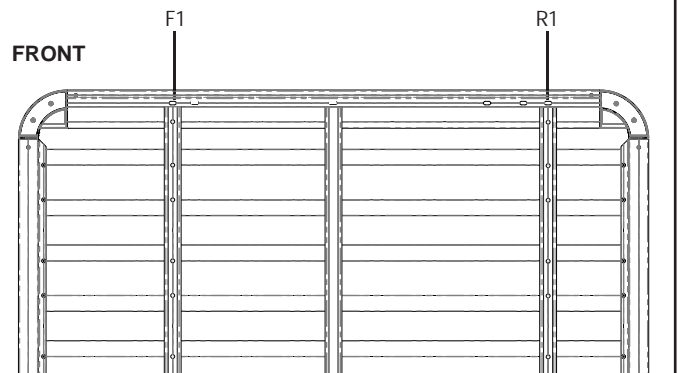

10 After underbars have been correctly fitted, place the Pioneer tray on top of the Backbone rails. Align the underbars with the top tabs and ensure the M8 hardware fits into underbar channel.

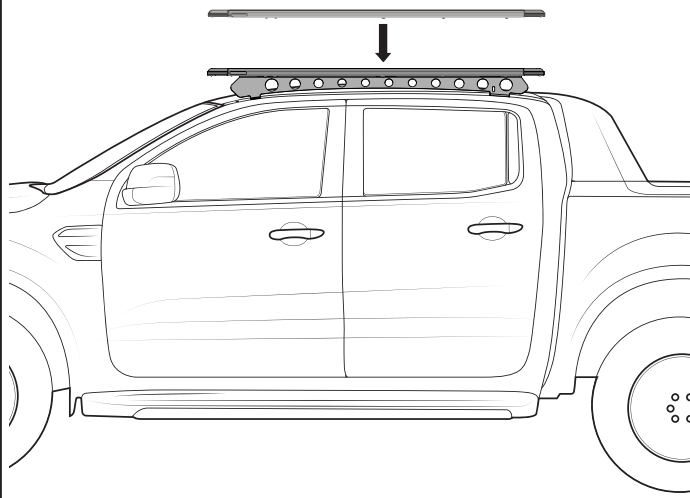

11 Once Pioneer underbars have been aligned properly, tighten all M8 hardware using 13mm socket wrench or 13mm spanner. Ensure channel nut has rotated within Pioneer underbar and is fixing Pioneer securely. Tighten to 8-10Nm (6-7lbs/ft).

