



RHINO-RACK

Aerodynamic & Heavy Duty Roof Rack Systems

RLCP12 SUZUKI Grand Vitara 2 & 4 Door - Two Cross Bars

Important: Please read these instructions carefully prior to installation. Please refer to your fitting instruction to ensure that the roof racks are installed in the correct locations. Check the contents of kit before commencing fitment and report any discrepancies. Place these instructions in the vehicle's glove box after installation is complete.

Layout:

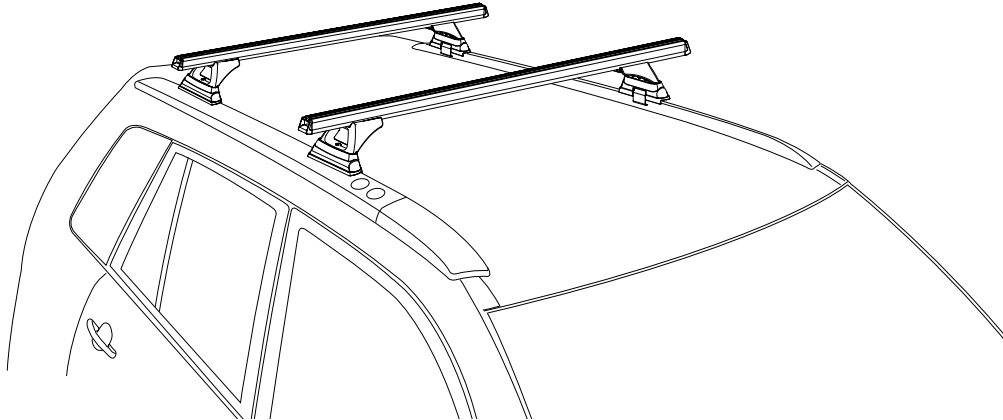

IMPORTANT Care Instruction:

Thoroughly clean roof rails prior to fitting roof racks. PLEASE READ THROUGH INSTRUCTIONS BEFORE FITTING.

Important Information

Maximum carrying capacity: 50kg evenly distributed over the two cross bars.

Recommendations:

It is essential that all bolt connections be checked after driving a short distance when you first install your cross bars. Bolt connections should be checked again at regular intervals (probably once a week is enough, depending on road conditions, usage, loads and distances travelled). You should also check the cross bars each time they are refitted.

Make sure to fasten your load securely. Please ensure that all loads are evenly distributed and that the centre of gravity is kept as low as possible.

Use only non-stretch fastening ropes or straps.

Sensitivity to cross winds, behaviour in curves and braking.

The handling characteristics of the vehicle, changes when you transport a load on the roof. For safety reasons, we recommend you exercise extreme care when transporting wind-resisting loads; special consideration must be taken into account when braking.

Please remove cross bars when putting vehicle through an automatic car wash.

Load rating.

Maximum permissible load is 50kg per pair of cross bars (include the weight of the roof racks, 5kg). When cross bars are to be used in off-road conditions, please build a safety factor of 1.5 into this load limit. (33kg for off-road use). Although the roof racks are tested and approved to AS1235-2000, Australian road conditions can be much more rigorous. However, increasing the number of cross bars does not increase the vehicles maximum permissible roof loading.

Note for Dealers and Fitters.

It is your responsibility to ensure instructions are given to the end user or client

Rhino-Rack
3 Pike Street, Rydalmere,
NSW 2116, Australia.
(Ph) (02) 9638 4744
(Fax) (02) 9638 4822

Document No: RS-312
Prepared By: Craig Jones
Authorised By: Gary England

Issue No: 03
Issue Date: 30/03/2009

These instructions remain the property of Rhino Rack Australia Pty. Ltd. and may not be used or changed for any other purpose than intended.



SUZUKI Grand Vitara 2 & 4 Door - Two Cross Bars

Parts List

Maximum carrying capacity: 50kg evenly distributed over the two cross bars.

Item	Component Name	Qty	Part No.
1	Heavy Duty Rubber Buffer 1250mm	2	A019
2	Heavy Duty End Cap	4	M002
3	Heavy Duty Cross Bar 1250mm	2	R003
4	M6 x 40mm Security Screw	4	B085
5	M6 Spring Washer	4	W004
6	M6 x 12.5mm Flat Washer	4	W003
7	RLCP Leg	4	M123
8	Top Pad	4	M173
9	Vitara Bottom Pad	4	M258
10	Vitara Bracket with Cage Nut	4	C572
11	M10 x 25mm Hex Bolt	4	B071
12	M10 Internal Shakeproof Washer	4	W021
13	M10 x 38mm Flat Washer	4	W022
14	M10 Channel Nut	4	N024
15	5mm Security Allen Key	1	H021
16	Fitting Instruction	1	RS-312

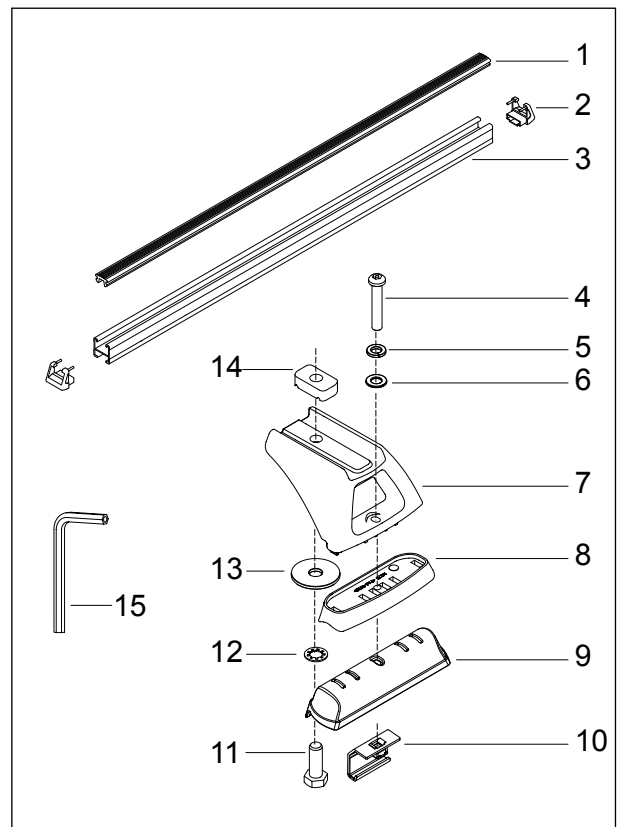

Tools Required;

Allen key, included in kit.
5/8 or 16mm Spanner.

Side Cutters.
Rubber Mallet.
Tape Measure.

1

Top pad location tangs face outside of vehicle.

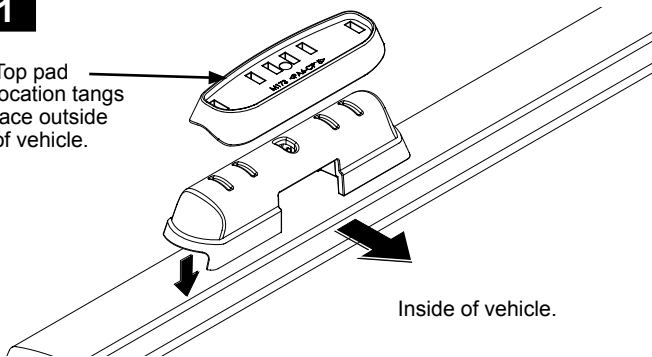

The four top and bottom pads are identical. Diagram at left shows correct orientation of top and bottom pad. The large cut out and lip of the bottom pad sits over the inside edge of the roof rail.

2

4 door Vitara: Place the pads between the round plastic covers on the roof rail at a spacing of 750mm.

2 door Vitara: Place the edge of the pads 125mm from the join in the roof rail.

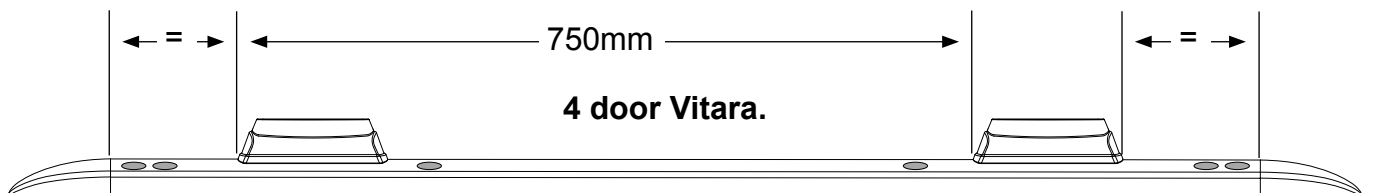



SUZUKI Grand Vitara 2 & 4 Door - Two Cross Bars

3

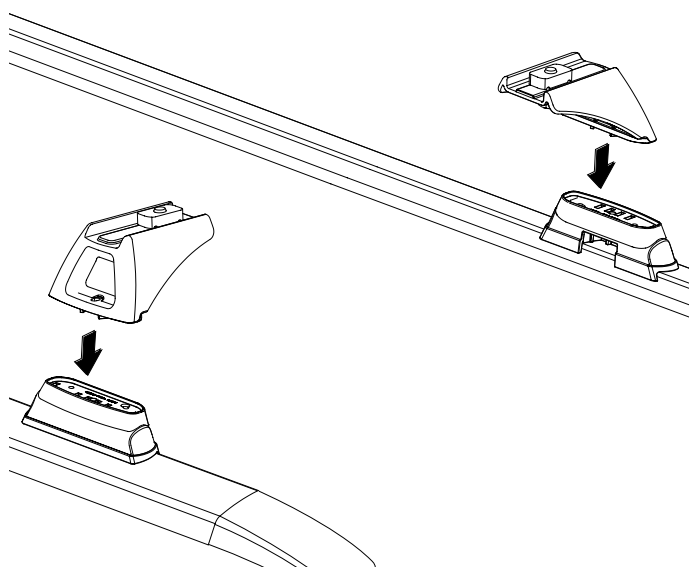

This step combines with following Step 4. Place each leg onto a pad.

Assemble M6 screw and washers in preparation for next step.

M6 x 40mm screw

Spring washer

Flat washer

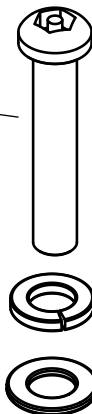

4

Place a stainless steel bracket into the inside of the cut out in the base pad. While holding the leg and pads insert the screw / washer assembly through the leg and into the cage nut. Make sure the bracket is properly located under the inside lip of the roof rail. **Do not fully tighten at this stage.**

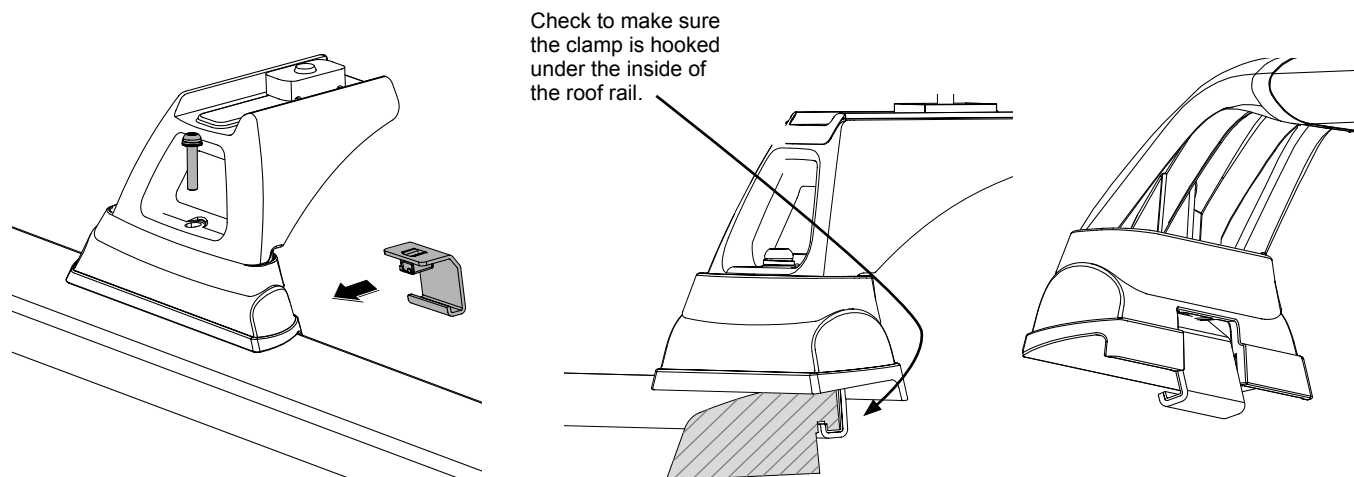

5

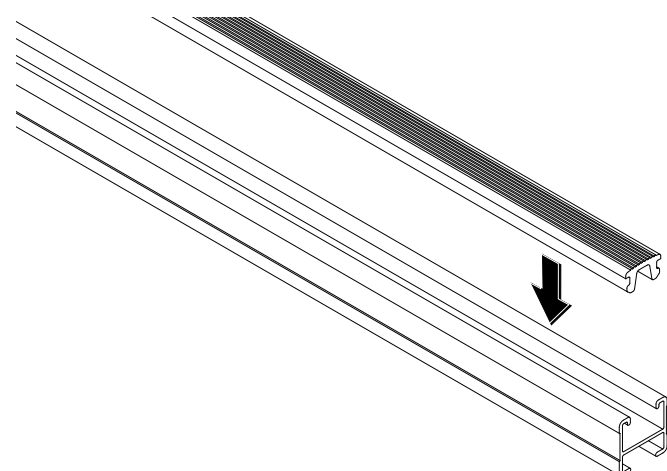

Insert cross bar rubber buffer strip into the top of the cross bar.

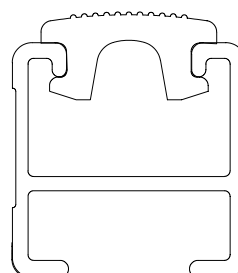



SUZUKI Grand Vitara 2 & 4 Door - Two Cross Bars

6

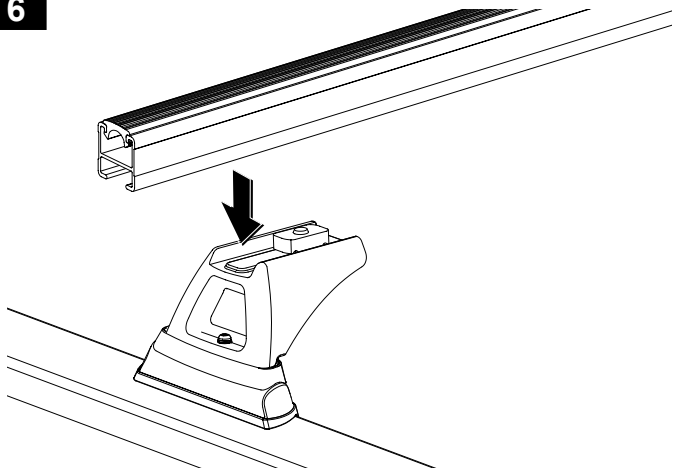

Place each cross bar onto the legs. Make sure the channel nut sits across the bar as shown below.

Channel nut must sit across the cross bar when tight.

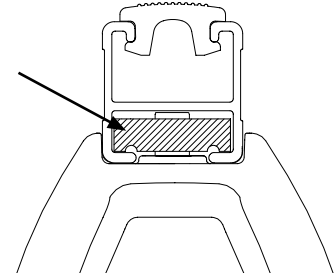

7

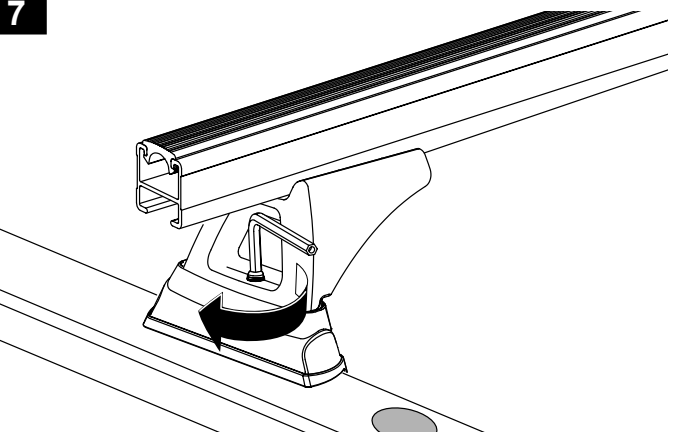

Tighten the four M6 x 40mm security screws to 9-10 Nm.

8

Adjust the cross bar by sliding side to side to achieve equal over hang. Using a 16mm spanner tighten the hex bolt on the under side of the leg to 12-15 Nm.

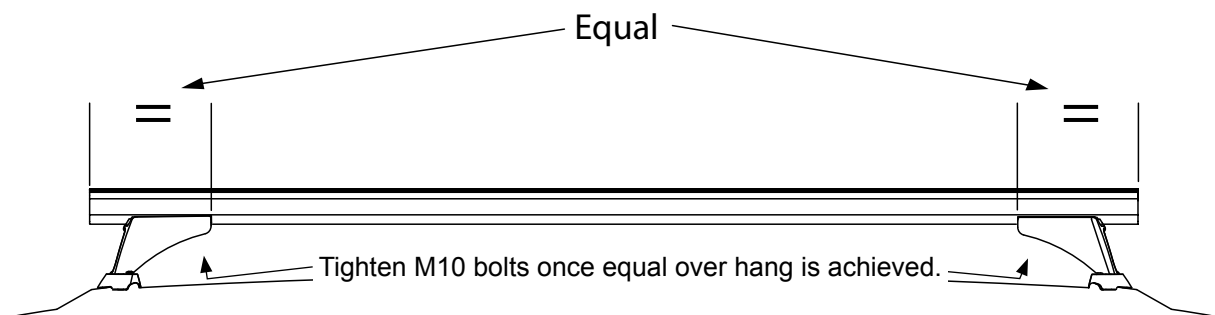

9

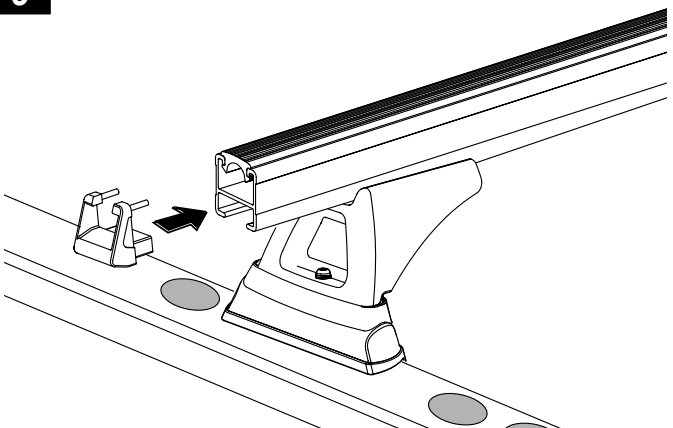

The rubber buffer may have to be trimmed level with the end of the cross bar before inserting the end caps. Push the end caps into the cross bars, a rubber mallet may be needed to tap these in.