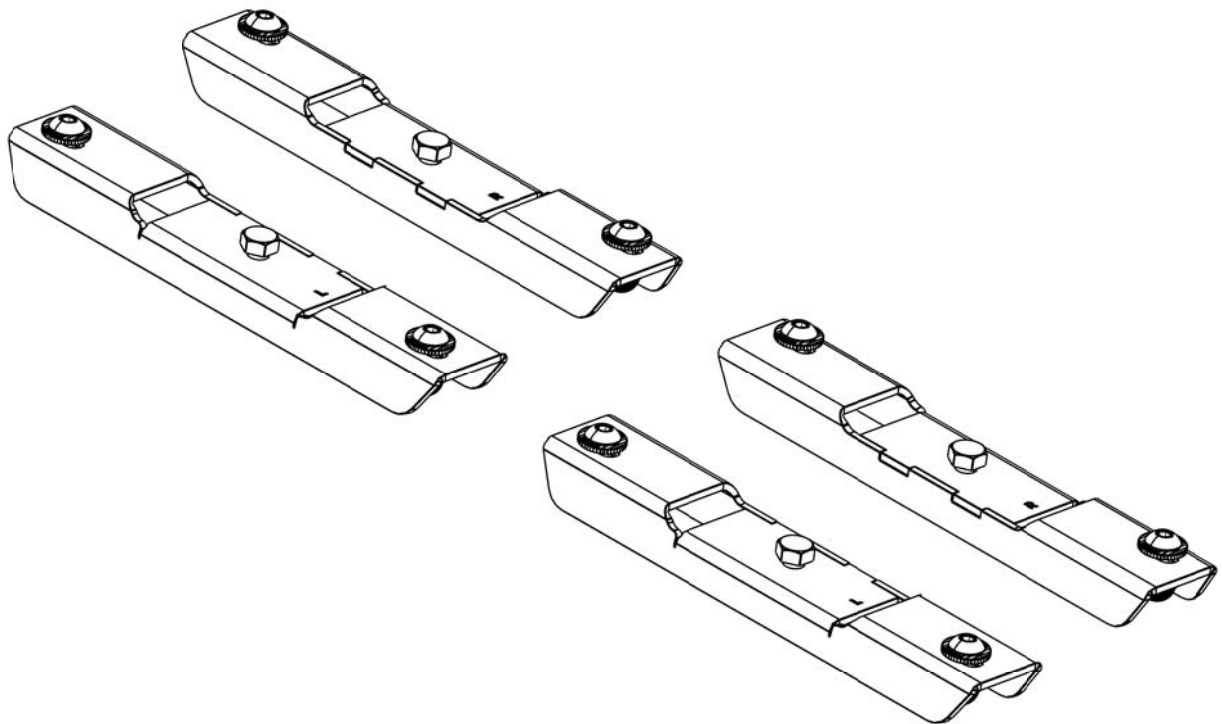

**INSTALL TIME: 15 mins****IMPORTANT WARNING!**

IT IS CRITICAL THAT ALL FRONT RUNNER PRODUCTS BE PROPERLY AND SECURELY ASSEMBLED AND ATTACHED TO YOUR VEHICLE. IMPROPER ATTACHMENT COULD RESULT IN AN AUTOMOBILE ACCIDENT, AND COULD CAUSE SERIOUS BODILY INJURY OR DEATH TO YOU OR TO OTHERS. YOU ARE RESPONSIBLE FOR ASSEMBLING AND SECURING ALL FRONT RUNNER PRODUCTS TO YOUR VEHICLE, CHECKING THE ATTACHMENTS PRIOR TO USE, AND PERIODICALLY INSPECTING THE PRODUCTS FOR ADJUSTMENT, WEAR, AND DAMAGE. THEREFORE, YOU MUST READ AND UNDERSTAND ALL OF THE INSTRUCTIONS AND CAUTIONS SUPPLIED WITH YOUR FRONT RUNNER PRODUCT PRIOR TO INSTALLATION OR USE. IF YOU DO NOT UNDERSTAND ALL OF THE INSTRUCTIONS AND CAUTIONS, OR IF YOU HAVE NO MECHANICAL EXPERIENCE AND ARE NOT THOROUGHLY FAMILIAR WITH THE INSTALLATION PROCEDURES, YOU SHOULD HAVE THE PRODUCT INSTALLED BY A PROFESSIONAL INSTALLER OR OTHER QUALIFIED PERSONNEL.

1 GET ORGANIZED...

Here is what you are looking at:

Item #	Quantity	Description
1	8	M8 x 20 BUTTON HEAD BOLT
2	16	M8 x 19 FLAT WASHER
3	4	LOAD BAR ADAPTER - 2 LEFT, 2 RIGHT
4	12	M8 NYLOC NUT
5	12	M8 NUT CAP
6	4	M8 x 20 HEX BOLT
7	4	M8 FLAT WASHER

You will need:

- 13 mm Flat or Socket Wrench
- 5 mm Hex Key
- Measuring Tape

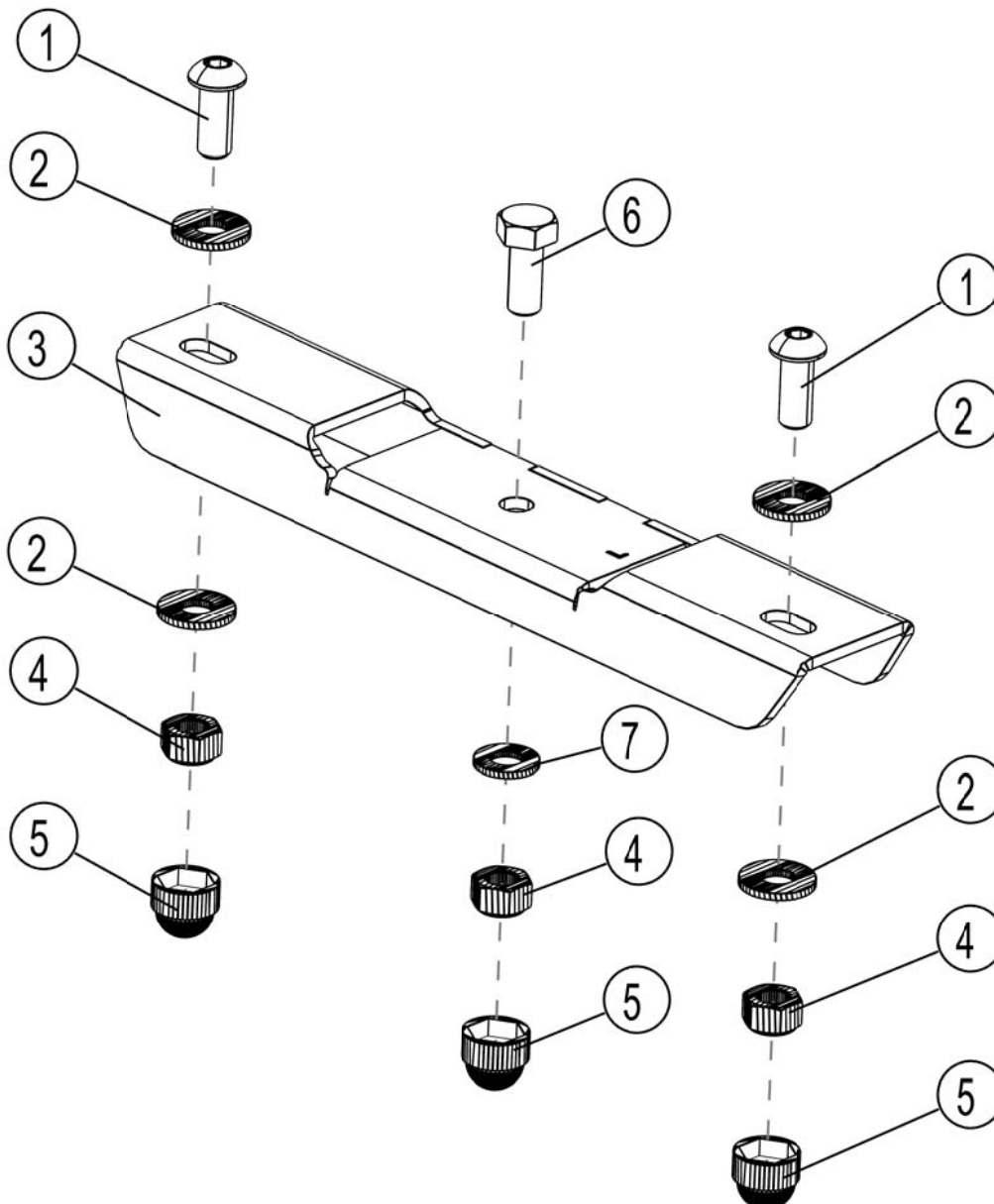

(A) Familiarize yourself with the parts and then step away from the work area and read through these instructions from beginning to end. Take a moment as a little prep now may save you a lot of time later.

2 INSTALL ADAPTER AND LOAD BARS

- (A) You would have received two Left Hand Side (Indicated by the letter L) and two Right Hand Side (Indicated by the letter R) Load Bar Adapters. Fasten the corresponding Adapters (Item 3) to the inside of the Foot Rails using the M8 x 20 Button Head Bolts, M8 x 19 Flat Washers and M8 Nyloc Nuts (Items 1, 2, 4) as shown. Note the mounting slots are offset to one side. Ensure that the offset goes towards the inside of the Foot Rail. Place a M8 Nut Cap (Item 5) over each of the M8 Nyloc Nuts.

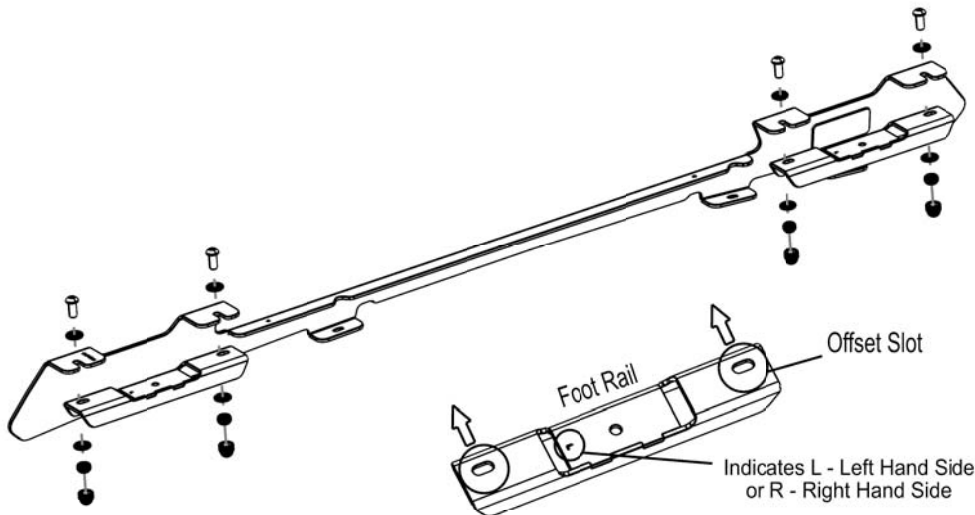

- (B) Referring to the Fitting Instruction (Document WDLB001) received with your Wind Deflector, fit a Wind Deflector to each of the Load Bars.

- (C) With the Load Bar still in the upside down position (Wind Deflector on top), insert a M8 x 20 Hex Bolt (Item 6) into each end of the Load Bars through the machined slots as shown. Flip the Load Bars into the upright position (Wind Deflector underneath) and loosely secure the Load Bars to the Load Bar Adapters using the remaining M8 Flat Washers and M8 Nyloc Nuts (Items 2, 6, 7) as shown. Ensure that the Lip on the Wind Deflector goes towards the rear of the vehicle. Center the Load Bars, left to right and tighten the Nyloc Nuts. Place a M8 Nut Cap (Item 5) over each of the Nyloc Nuts.

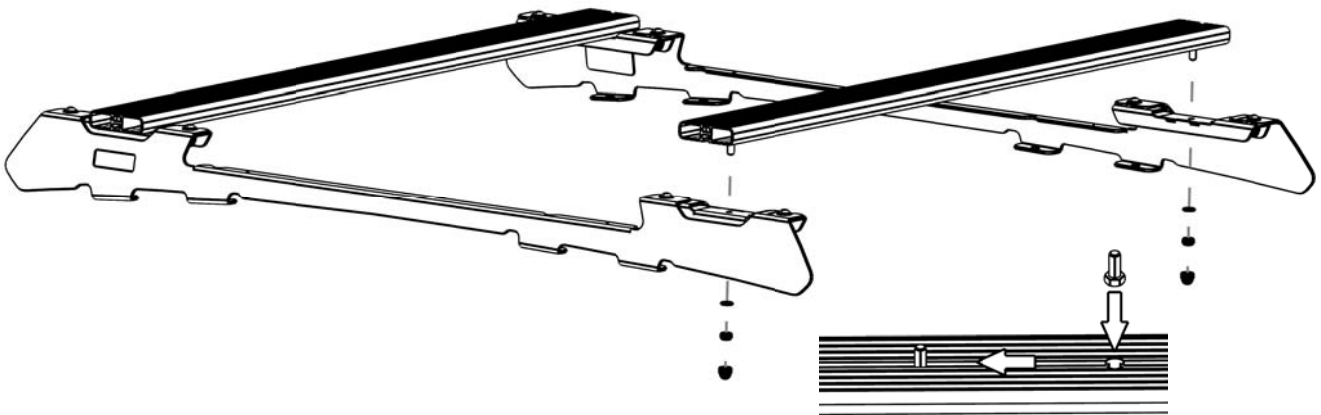

2 INSTALL ADAPTER AND LOAD BARS CONT...

(D) Fit a Plastic End Cap into each end of the Load Bars as shown.

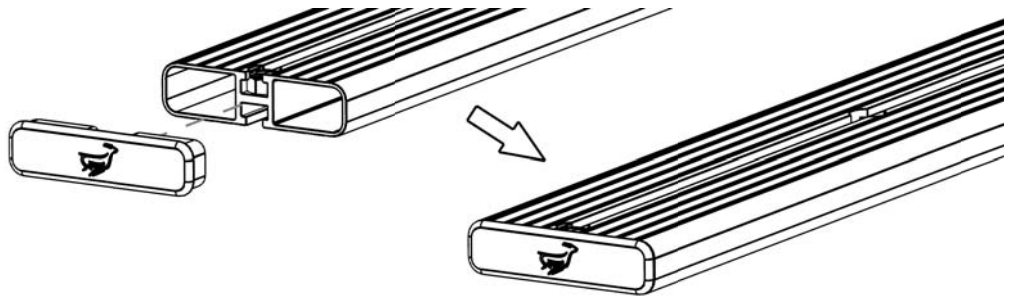

(C) Congratulations, you have completed your installation. Take a step back and admire your work. Good Job!

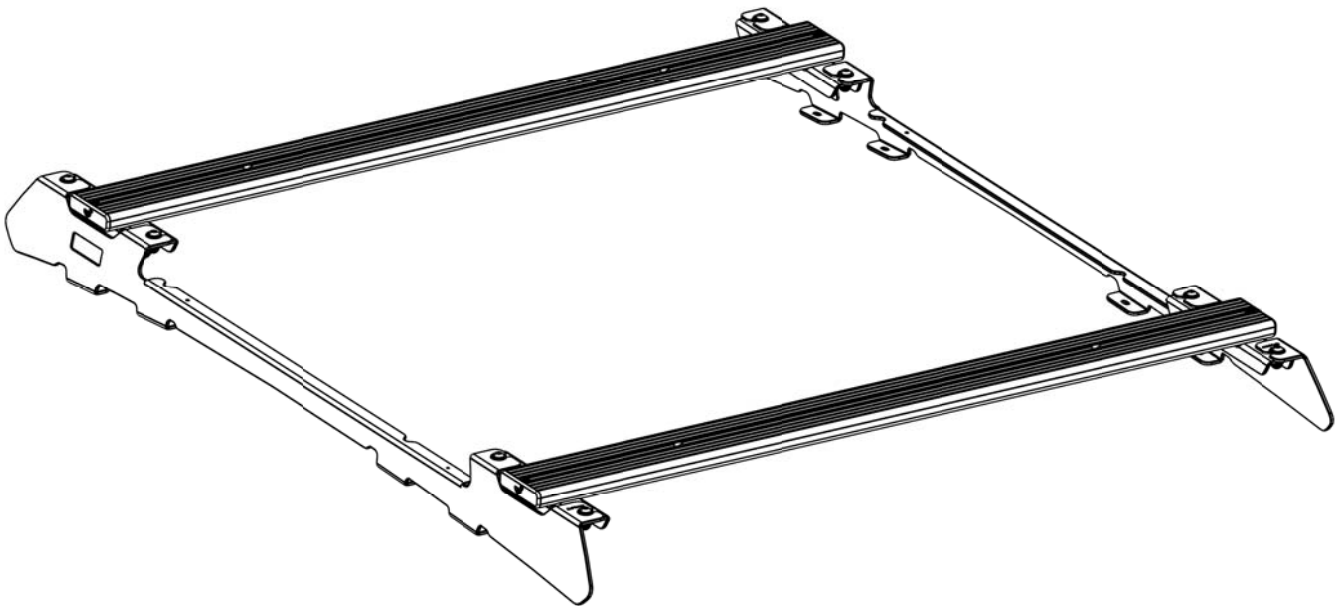

3 INSTALL OTHER VEHICLE AND RACK ACCESSORIES

(A) Now's the time to visit your favorite Front Runner dealer in person or online.

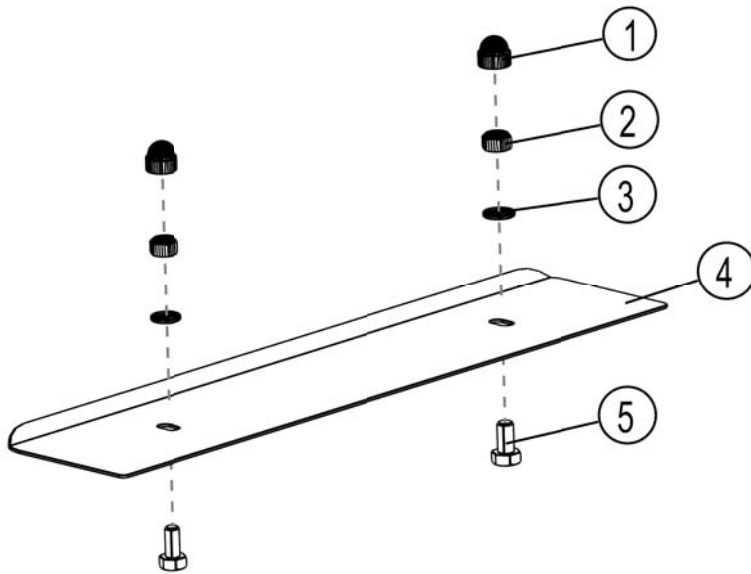
**1****You will need:**

- 13 mm Flat or Socket Wrench
- Measuring Tape

Item #	Quantity	Description
1	2	M8 NUT CAP
2	2	M8 NYLOC NUT
3	2	M8 FLAT WASHER
4	1	WIND DEFLECTOR
5	2	M8 x 16 HEX BOLT

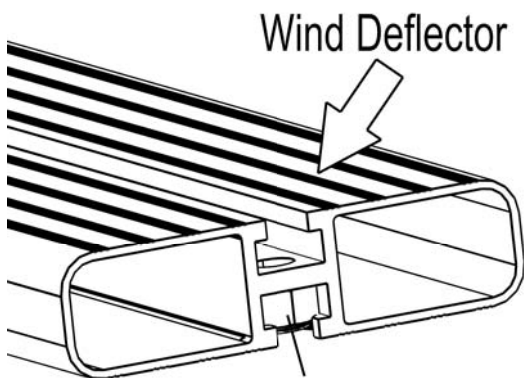
2

Ensure pre installed Nyloc Nuts are to the Bottom

