

# 48001837



Checklist / Manual de Montagem - Pára-choques Ranger T6 - Faróis de nevoeiro incluído



Checklist / Fitting Instructions - Front bull bar Ranger T6 - Fog lights included



Despiezas / Instrucciones de montaje -



<b>1</b> x1 4800219		<b>2</b> x1 4800219		<b>3</b> x1 4800212		<b>4</b> x1 4700163	
<b>5</b> x2 4700000		<b>6</b> x1 4600459		<b>7</b> x1 4600458		<b>8</b> x1 4600456	
<b>9</b> x1 4600456		<b>10</b> x1 4600456		<b>11</b> x1 4600456		<b>12</b> x1 4600456	
<b>13</b> x1 4600456		<b>14</b> x1 4500046		<b>15</b> x1 4500032		<b>15</b> x1 4500033	
<b>16</b> x1 4500007		<b>16</b> x1 4500011		<b>17</b> x1 4500006		<b>17</b> x1 4500006	
<b>18</b> x1 4500004		<b>18</b> x1 4500005		<b>19</b> x1 4500003		<b>20</b> x1 4500033	
<b>20</b> x1 4500001		<b>21</b> x1 4500001		<b>21</b> x1 4500000			

Ford Ranger T6 Cab. Dupla (2012- )      Ford Ranger T6 Cab. Dupla (2012- )

Thank you for choosing AFN products, a lot of time in R&D has gone into perfecting our products. However, if you find problems with any AFN products you have purchased, or if you have any information which would help us to improve our products, please let us know.

If you think there may be a problem either before or after fitting the AFN product, it is best to contact your nearest AFN distributor.

## **WARNING**

- This product should be installed as demonstrated in the product fitting instructions.
- If verified that any component is damaged, please contact your nearest AFN distributor.
- The specified parts, will only fit the models specified by AFN.
- Do not modify any component of the product.
- It is recommended that this product is installed by specialised and trained personnel.
- AFN cannot be responsible for any changes made by the vehicle manufacturer.
- Work safely and use specialised tools at all times.
- Always use protective gear.



size	Torque Nm	Torque lbft
M6	9Nm	4 lbft
M8	22Nm	16 lbft
M10	44Nm	32 lbft
M12	77Nm	57 lbft

- Tools set required:



### **CONTACTS**

R. da Madeira, nº 113  
Z. Industrial das Travessas  
3700-176 S. João da Madeira  
Portugal

Tel.: (+351) 256 838 300  
Fax: (+351) 256 838 305  
www.afn.pt  
geral@afn.pt

### **COORDINATES**

DATUM: European 79  
UTM 05.44.100  
29T 45.28.300  
N 40°54' 14.0"  
W 08°28' 35.0"

**01**



- Cut the original bumper.
- Make sure you use protective gear.



**02**

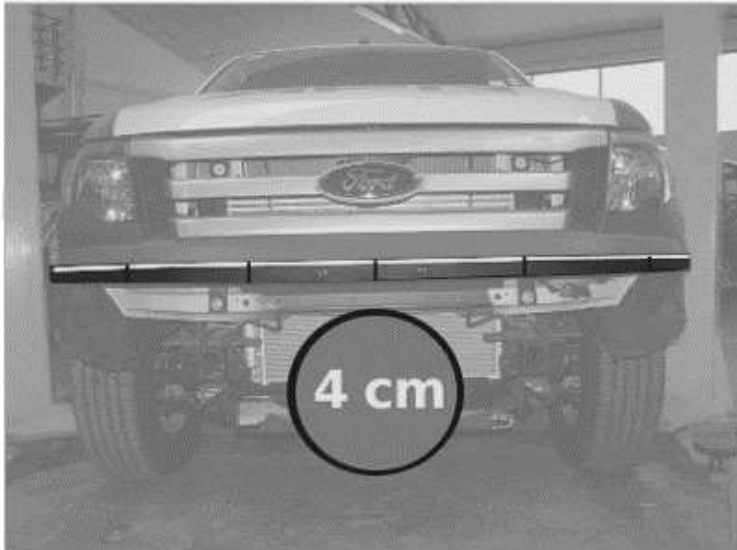

- From the line of the OEM bumper measure 4cm down.
- After marked with tape, cut the OEM bumper.
- Use the image as reference.

**03**



- Use parts number  
46004560/46004561  
46004562/46004563
- 1- bolts needed  
45000067/45000042  
45000066
- 2- After fitting the above part numbers, fit 46004564 with bolt number  
45000329/45000338/45000330

04

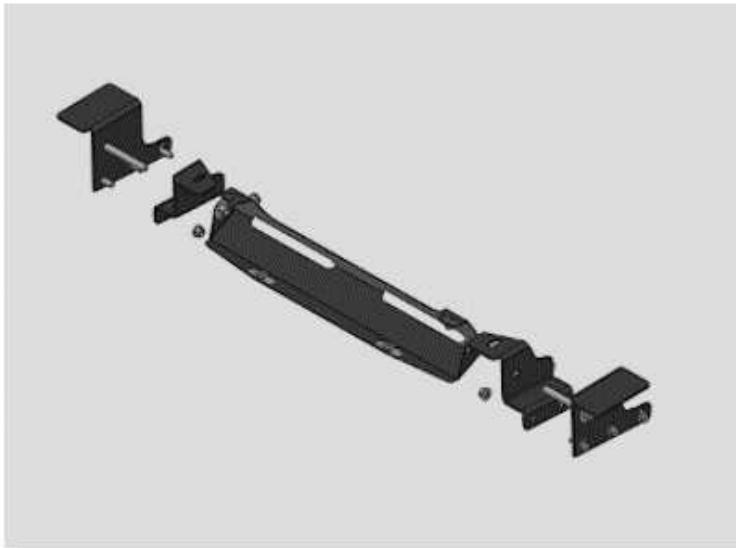

- Use this image as reference for the previous step.

05

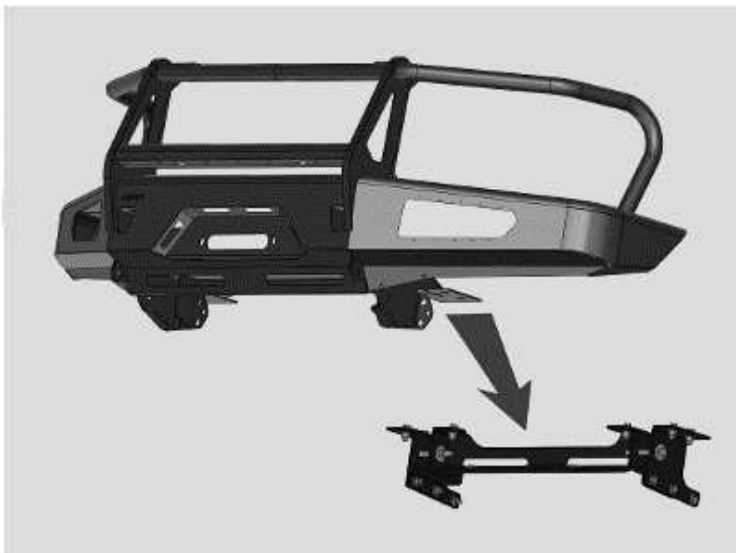

- Place th AFN bumper ref: 47001270 on the previously mounted parts.

06



- Bolts needed to fit the AFN bumper:

- 1- 45000007/45000010/47000017
- 2- 45000042/45000066/47000067

- Repeat the step on the opposite side.  
 - Please finger tight all the bolts before do the final torque.  
 (use the table shown in the first page).

**07**

- Fit the part number 46004565

- Bolts needed:  
45000110

**08**

- Fit the parts number:  
46004589/46004590

- Bolts needed:  
45000050/45000462/45000074

- Make sure you gave the final  
torque in all the bolts.  
(use the table shown in the first  
page).

**09**

